



RADIO TEST REPORT

REPORT NO.: RE981105L13

MODEL NO.: EP801

RECEIVED: Nov. 05, 2009

TESTED: Nov. 05, 2009 ~ Jan. 09, 2010

ISSUED: Jan. 20, 2010

APPLICANT: Senao Networks, Inc.

ADDRESS: 3F, No. 529, Chung Cheng Rd., Hsintien, Taipei,
Taiwan, R.O.C.

ISSUED BY: Bureau Veritas Consumer Products Services
(H.K.) Ltd., Taoyuan Branch

LAB ADDRESS: No. 47, 14th Ling, Chia Pau Tsuen, Lin Kou
Hsiang, Taipei Hsien 244, Taiwan, R.O.C.

TEST LOCATION: No. 19, Hwa Ya 2nd Rd, Wen Hwa Tsuen, Kwei
Shan Hsiang, Taoyuan Hsien 333, Taiwan, R.O.C.

This test report consists of 70 pages in total. It may be duplicated completely for legal use with the approval of the applicant. It should not be reproduced except in full, without the written approval of our laboratory. The client should not use it to claim product endorsement by TAF or any government agencies. The test results in the report only apply to the tested sample.





TABLE OF CONTENTS

1.	CERTIFICATION	3
2.	SUMMARY OF TEST RESULTS	4
2.1.	TEST INSTRUMENTS	5
2.2.	MEASUREMENT UNCERTAINTY	6
2.3.	MAXIMUM MEASUREMENT UNCERTAINTY	6
3.	GENERAL INFORMATION	7
3.1.	GENERAL DESCRIPTION OF EUT	7
3.2.	DESCRIPTION OF TEST MODES	8
3.2.1	CONFIGURATION OF SYSTEM UNDER TEST	9
3.2.2	TEST MODE APPLICABILITY AND TESTED CHANNEL DETAIL	10
3.3.	GENERAL DESCRIPTION OF APPLIED STANDARDS	12
3.4.	DESCRIPTION OF SUPPORT UNITS	12
	TRANSMITTER PARAMETERS	13
4.	TEST PROCEDURES AND RESULTS	13
4.1.	FREQUENCY ERROR	13
4.1.1.	LIMIT OF FREQUENCY ERROR	13
4.1.2.	TEST PROCEDURES	13
4.1.3.	DEVIATION FROM TEST STANDARD	13
4.1.4.	TEST SETUP	13
4.1.5.	TEST RESULTS	14
4.2.	CARRIER POWER	16
4.2.1.	LIMIT OF CARRIER POWER	16
4.2.2.	TEST PROCEDURES	16
4.2.3.	DEVIATION FROM TEST STANDARD	16
4.2.4.	TEST SETUP	16
4.2.5.	TEST RESULTS	17
4.3.	CHANNEL BANDWIDTH	18
4.3.1.	LIMIT OF CHANNEL BANDWIDTH	18
4.3.2.	TEST PROCEDURES	18
4.3.3.	DEVIATION FROM TEST STANDARD	18
4.3.4.	TEST SETUP	18
4.3.5.	TEST RESULTS	19
4.4.	SPURIOUS EMISSIONS	42
4.4.1.	LIMITS OF SPURIOUS EMISSIONS	42
4.4.2.	TEST PROCEDURES	42
4.4.3.	DEVIATION FROM TEST STANDARD	42
4.4.4.	TEST SETUP	42
4.4.5.	TEST RESULTS	43
	RECEIVER PARAMETERS	59
4.5.	RECEIVER SPURIOUS RADIATION	59
4.5.1.	LIMIT OF RECEIVER SPURIOUS RADIATION	59
4.5.2.	TEST PROCEDURES	59
4.5.3.	DEVIATION FROM TEST STANDARD	59
4.5.4.	TEST SETUP	59
4.5.5.	TEST RESULTS	60
5.	PHOTOGRAPHS OF THE TEST CONFIGURATION	66
6.	INFORMATION ON THE TESTING LABORATORIES	70



1. CERTIFICATION

PRODUCT: Digital Long Range Cordless System
MODEL NO.: EP801
BRAND: EnGenius
APPLICANT: Senao Networks, Inc.
TESTED: Nov. 05, 2009 ~ Jan. 09, 2010
TEST SAMPLE: ENGINEERING SAMPLE
STANDARD: EN 301 357-1 V1.4.1 (2008-11)
EN 301 357-2 V1.4.1 (2008-11)

The above equipment (model: EP801) has been tested by **Bureau Veritas Consumer Products Services (H.K.) Ltd., Taoyuan Branch**, and found compliance with the requirement of the above standards. The test record, data evaluation & Equipment Under Test (EUT) configurations represented herein are true and accurate accounts of the measurements of the sample's EMC characteristics under the conditions specified in this report.

PREPARED BY : Andrea Hsia , **DATE :** Jan. 20, 2010
Andrea Hsia / Specialist

TECHNICAL ACCEPTANCE : Mason Chang , **DATE :** Jan. 20, 2010
Responsible for RF Mason Chang / Engineer

APPROVED BY : Gary Chang , **DATE :** Jan. 20, 2010
Gary Chang / Assistant Manager

2. SUMMARY OF TEST RESULTS

The EUT has been tested according to the following specifications:

APPLIED STANDARD: ETSI EN 301 357-1 V1.4.1 (2008-11) EN 301 357-2 V1.4.1 (2008-11)			
CLAUSE IN ETSI EN 301 357-1	TEST PARAMETER	TEST APPLICABILITY	RESULT
	TRANSMITTER PARAMETERS		
8.3	Frequency error	Applicable	Pass
8.4	Carrier power	Applicable	Pass
8.5	Channel bandwidth	Applicable	Pass
8.6	Spurious emissions	Applicable	Pass
8.7	Cordless audio transmitter shutoff	NOTE	NOTE
	RECEIVER PARAMETERS		
9.1	Spurious emissions	Applicable	Pass

NOTE: For this test parameter, client will provide the test result by themselves.



2.1. TEST INSTRUMENTS

DESCRIPTION & MANUFACTURER	MODEL NO.	SERIAL NO.	DATE OF CALIBRATION	DUE DATE OF CALIBRATION
Spectrum Analyzer Agilent	E4446A	MY48250266	Aug. 08, 2009	Aug. 07, 2010
BILOG Antenna SCHWARZBECK	VULB 9168	9168-161	Apr. 29, 2009	Apr. 28, 2010
HORN Antenna ETS	3117	00034130	Jan. 12, 2010	Jan. 11, 2011
Signal Generator Agilent	E8257C	MY43320668	Dec. 31, 2009	Dec. 30, 2010
Preamplifier Agilent	8449B	3008A01976	Nov. 13, 2009	Nov. 12, 2010
Preamplifier Agilent	8447D	2944A10639	Nov. 16, 2009	Nov. 15, 2010
RF signal cable HUBER+SUHNER	SUCOFLEX 104	254644/4	Aug. 28, 2009	Aug. 27, 2010
RF signal cable HUBER+SUHNER	SUCOFLEX 104	251640/4	Aug. 28, 2009	Aug. 27, 2010
Software ADT.	ADT_Radiated_ V7.6.15.9.2	NA	NA	NA
Antenna Tower Inn-co GmbH	MA 4000	MA 4000/013/6150303/L	NA	NA
Turn Table ADT	NA	SN30303	NA	NA
Controller TDK RF	SI-300	1200015	NA	NA
Temperature & Humidity chamber TERCHY	MHU-225AU	920842	Jun. 22, 2009	Jun. 21, 2010

- NOTE:** 1. The calibration interval of the above test instruments is 12 months and the calibrations are traceable to NML/ROC and NIST/USA.
 2. The test was performed in HwaYa RF Chamber 2.
 3. The horn antenna and HP preamplifier (model: 8449B) are used only for the measurement of emission frequency above 1GHz if tested.

2.2. MEASUREMENT UNCERTAINTY

Where relevant, the following measurement uncertainty levels have been estimated for tests performed on the EUT:

PARAMETER	UNCERTAINTY
RF frequency	$< \pm 1 \times 10^{-7}$
Audio output power	$< \pm 0,5$ dB
Radiated RF power	$< \pm 6$ dB
Conducted RF power variations using a test fixture	$< \pm 0,75$ dB
Maximum frequency deviation:	$< \pm 5$ %
Deviation limitation	$< \pm 5$ %
Radiated emission of transmitter, valid up to 12,75 GHz	$< \pm 6$ dB
Radiated emission of receiver, valid up to 12,75 GHz	$< \pm 6$ dB

2.3. MAXIMUM MEASUREMENT UNCERTAINTY

For the test methods, according to ETSI EN 301 357-2 standard, the measurement uncertainty figures shall be calculated in accordance with TR 100 028-1 [4] and shall correspond to an expansion factor (coverage factor) $k = 1,96$ or $k = 2$ (which provide confidence levels of respectively 95 % and 95,45 % in the case where the distributions characterizing the actual measurement uncertainties are normal (Gaussian)).

Maximum measurement uncertainty

PARAMETER	UNCERTAINTY
RF frequency	$\pm 3.57 \times 10^{-8}$
Audio output power	± 0.4 dB
Radiated RF power	± 2.855 dB
Conducted RF power variations using a test fixture	± 0.66 dB
Maximum frequency deviation:	± 1.2 %
Deviation limitation	± 1.2 %
Radiated emission of transmitter, valid up to 12,75 GHz	± 3.281 dB
Radiated emission of receiver, valid up to 12,75 GHz	± 3.282 dB



A D T

3. GENERAL INFORMATION

3.1. GENERAL DESCRIPTION OF EUT

PRODUCT	Digital Long Range Cordless System		
MODEL NO.	EP801		
NOMINAL VOLTAGE	12Vdc (from AC Adapter) 3.7Vdc (from battery) 5.5Vdc (from charger)		
VOLTAGE OPERATING RANGE	$V_{nom}= 230$	$V_{min}= 207$	$V_{max}= 253$
	$V_{nom}= 3.7$	$V_{min}= 3.1$	
TEMPERATURE OPERATING RANGE	0~55°C (Base Station) -10~60°C (Portable Handset)		
MODULATION TYPE	GMSK		
OPERATING FREQUENCY	863.08 ~ 864.93MHz		
NUMBER OF CHANNEL	38		
EIRP POWER	9.52dBm (Measured Max. Average)		
ANTENNA TYPE	Dipole antenna with 2dBi gain (Base Station) Dipole antenna with 2.5dBi gain (long Ant. Portable Handset) Dipole antenna with 1.5dBi gain (short Ant. Portable Handset)		
DATA CABLE	0.6m non-shielded cable without core		
I/O PORT	Refer to user's manual		
ACCESSORY DEVICE	Adapter, charger, Battery		

NOTE:

1. The EUT uses following adapters, battery & Charger.

ADAPTER (for Base Station used)	
BRAND	DVE
MODEL	DSA-12G-12 FEU 120120
INPUT POWER	100-240Vac, 50/60Hz, 0.3A
OUTPUT POWER	12Vdc, 1A
POEWR LINE	1.8m non-shielded cable without core

BATTERY (for Base Station used)	
BRAND	EnGenius
INPUT POWER	1100mAh
OUTPUT POWER	3.7Vdc

ADAPTER (for Charger used)	
BRAND	FAIRWAY
MODEL	WRG10F-055B
INPUT POWER	100-240Vac, 47-63Hz, 0.3A
OUTPUT POWER	5.5Vdc, 1.5A
POEWR LINE	1.8m non-shielded cable with one core

2. A set of the EUT include Base station & Portable handset
3. The above EUT information was declared by manufacturer and for more detailed features description, please refer to the manufacturer's specifications or user's manual.

3.2. DESCRIPTION OF TEST MODES

38 channels were provided to this EUT.

CH	FREQUENCY (MHz)	CH	FREQUENCY (MHz)
1	863.08	20	864.03
2	863.13	21	864.08
3	863.18	22	864.13
4	863.23	23	864.18
5	863.28	24	864.23
6	863.33	25	864.28
7	863.38	26	864.33
8	863.43	27	864.38
9	863.48	28	864.43
10	863.53	29	864.48
11	863.58	30	864.53
12	863.63	31	864.58
13	863.68	32	864.63
14	863.73	33	864.68
15	863.78	34	864.73
16	863.83	35	864.78
17	863.88	36	864.83
18	863.93	37	864.88
19	863.98	38	864.93

3.2.1 CONFIGURATION OF SYSTEM UNDER TEST

TEST MODE A (Base Station Charger mode)

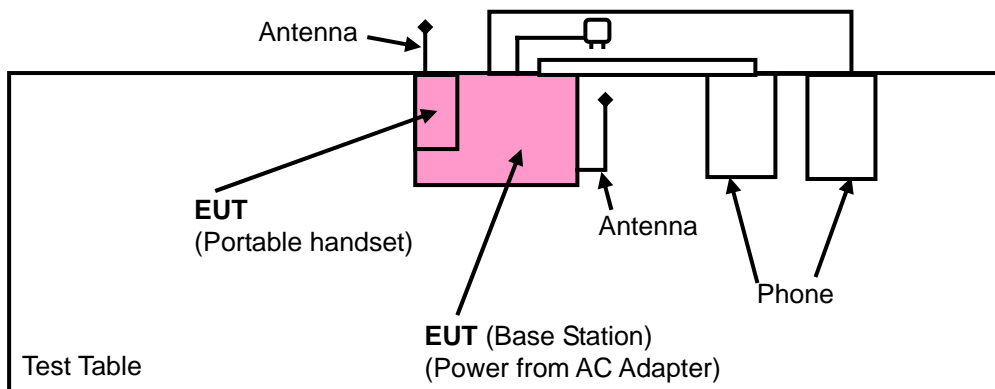

TEST MODE B (Base Station Standby mode)

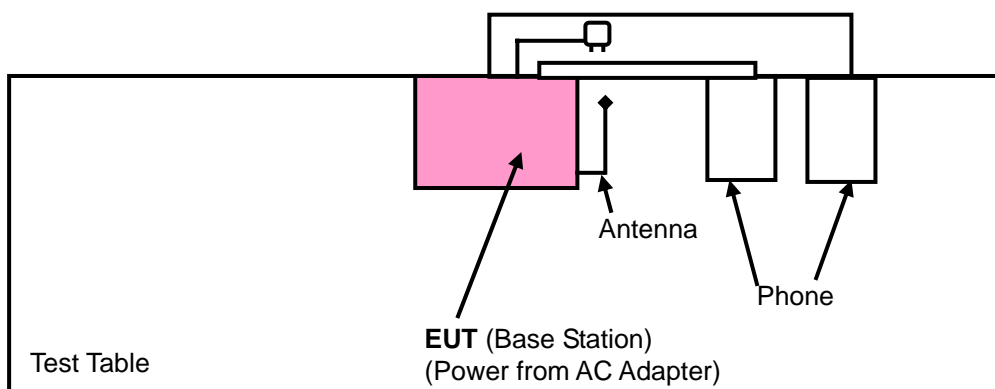

TEST MODE C (Handset Standby mode)

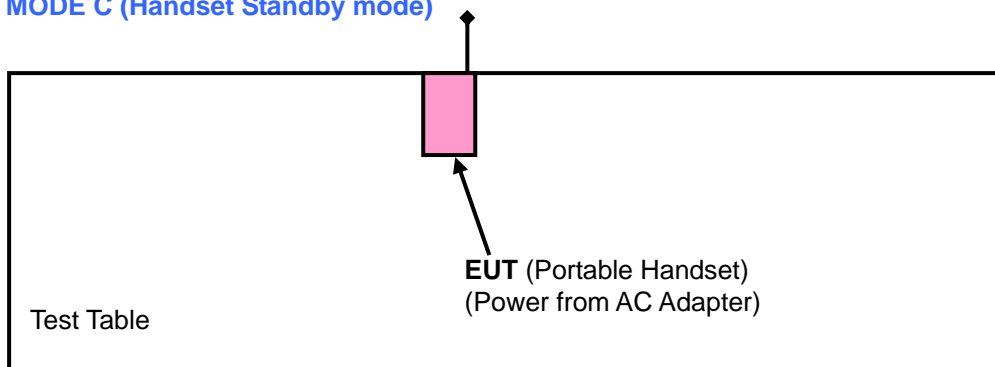

TEST MODE D (Handset Charger mode)

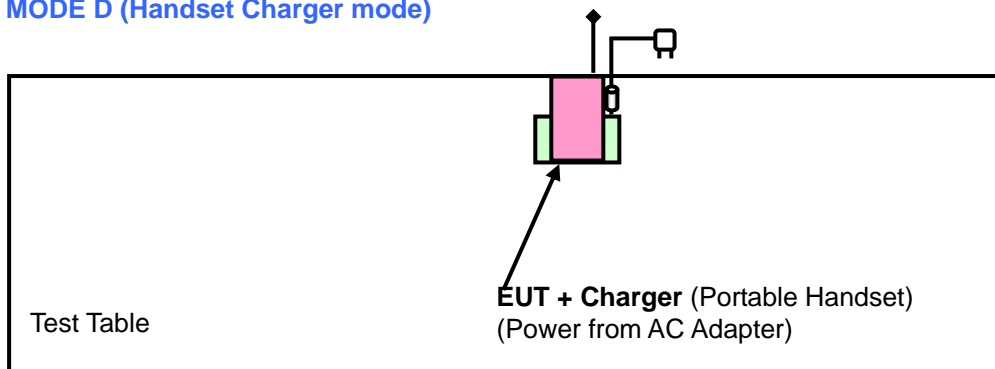

SPURIOUS EMISSIONS TEST (BELOW 1 GHz):

- Pre-Scan has been conducted to determine the worst-case mode from all possible combinations between available modulations, data rates and antenna ports (if EUT with antenna diversity architecture).
- Following channel(s) was (were) selected for the final test as listed below.

EUT CONFIGURE MODE	AVAILABLE CHANNEL	TESTED CHANNEL	MODULATION TYPE	AXIS
B	1 to 38	1	GMSK	X
C	1 to 38	1	GMSK	Z

SPURIOUS EMISSIONS TEST (ABOVE 1 GHz):

- Pre-Scan has been conducted to determine the worst-case mode from all possible combinations between available modulations, data rates and antenna ports (if EUT with antenna diversity architecture).
- Following channel(s) was (were) selected for the final test as listed below.

EUT CONFIGURE MODE	AVAILABLE CHANNEL	TESTED CHANNEL	MODULATION TYPE	AXIS
B	1 to 38	1	GMSK	X
C	1 to 38	1	GMSK	Z

TEST CONDITION:

APPLICABLE TO	ENVIRONMENTAL CONDITIONS	INPUT POWER (SYSTEM)	TESTED BY
FE	23 deg. C, 68% RH, 991 hPa	230Vac, 50Hz	Glen Chang
CP	23 deg. C, 68% RH, 991 hPa	230Vac, 50Hz	Glen Chang
CB	23 deg. C, 68% RH, 991 hPa	230Vac, 50Hz	Glen Chang
SE<1G	25 deg. C, 68% RH, 991 hPa	230Vac, 50Hz	Jack Li
SE ³ 1G	20 deg. C, 60% RH, 991 hPa	230Vac, 50Hz	Alex Huang

3.3. GENERAL DESCRIPTION OF APPLIED STANDARDS

The EUT is a RF product, according to the specifications of the manufacturers. It must comply with the requirements of the following standards:

EN 301 357-1 V1.4.1 (2008-11)

EN 301 357-2 V1.4.1 (2008-11)

All test items have been performed and recorded as per the above standards.

3.4. DESCRIPTION OF SUPPORT UNITS

The EUT has been tested as an independent unit together with other necessary accessories or support units. The following support units or accessories were used to form a representative test configuration during the tests.

NO.	PRODUCT	BRAND	MODEL NO.	SERIAL NO.	FCC ID
1	TELEPHONE	WONDER	WD-303	5C17DA09345	NA
2	TELEPHONE	WONDER	WD-303	5C17DA03116	NA

NO.	SIGNAL CABLE DESCRIPTION OF THE ABOVE SUPPORT UNITS
1	10m RJ11 cable
2	10m RJ11 cable

NOTE: All power cords of the above support units are non-shielded (1.8 m).

TRANSMITTER PARAMETERS

4. TEST PROCEDURES AND RESULTS

4.1. FREQUENCY ERROR

4.1.1. LIMIT OF FREQUENCY ERROR

Limit
$\pm 60\text{ppm}$

4.1.2. TEST PROCEDURES

Reference to ETSI EN 301 357-1 V1.4.1 clause 8.3.2.

4.1.3. DEVIATION FROM TEST STANDARD

No deviation.

4.1.4. TEST SETUP

For the actual test configuration, please refer to the related item in this test report (Photographs of the Test Configuration).

4.1.5. TEST RESULTS

FREQUENCY	CH1	TEST MODE	B
------------------	-----	------------------	---

TEST CONDITION			Carrier Frequency (MHz)	Frequency Drift (ppm)	Limit (ppm)
$T_{nom}(^{\circ}C)$	20	$V_{nom}(V)$	863.078826	-1.360245	± 60
$T_{min}(^{\circ}C)$	0	$V_{min}(V)$	863.078748	-1.450619	± 60
		$V_{max}(V)$	883.081748	2.025305	± 60
$T_{max}(^{\circ}C)$	50	$V_{min}(V)$	863.078927	-1.243222	± 60
		$V_{max}(V)$	863.081927	2.232701	± 60

FREQUENCY	CH19	TEST MODE	B
------------------	------	------------------	---

TEST CONDITION			Carrier Frequency (MHz)	Frequency Drift (ppm)	Limit (ppm)
$T_{nom}(^{\circ}C)$	20	$V_{nom}(V)$	863.980698	0.807889	± 60
$T_{min}(^{\circ}C)$	0	$V_{min}(V)$	863.971600	-9.722447	± 60
		$V_{max}(V)$	863.974600	-6.250145	± 60
$T_{max}(^{\circ}C)$	50	$V_{min}(V)$	863.980704	0.814834	± 60
		$V_{max}(V)$	863.983704	4.287136	± 60

FREQUENCY	CH38	TEST MODE	B
------------------	------	------------------	---

TEST CONDITION			Carrier Frequency (MHz)	Frequency Drift (ppm)	Limit (ppm)
$T_{nom}(^{\circ}C)$	20	$V_{nom}(V)$	864.932672	3.089267	± 60
$T_{min}(^{\circ}C)$	0	$V_{min}(V)$	864.941001	12.718948	± 60
		$V_{max}(V)$	864.944001	16.187437	± 60
$T_{max}(^{\circ}C)$	50	$V_{min}(V)$	864.932654	3.068456	± 60
		$V_{max}(V)$	864.935654	6.536945	± 60



A D T

FREQUENCY	CH1	TEST MODE	C
------------------	-----	------------------	---

TEST CONDITION			Carrier Frequency (MHz)	Frequency Drift (ppm)	Limit (ppm)
$T_{nom}(^{\circ}C)$	20	$V_{nom}(V)$	863.079541	-0.531816	± 60
$T_{min}(^{\circ}C)$	10	$V_{min}(V)$	863.079940	-0.069518	± 60
$T_{max}(^{\circ}C)$	60	$V_{min}(V)$	863.0797496	-0.290124	± 60

FREQUENCY	CH19	TEST MODE	C
------------------	------	------------------	---

TEST CONDITION			Carrier Frequency (MHz)	Frequency Drift (ppm)	Limit (ppm)
$T_{nom}(^{\circ}C)$	20	$V_{nom}(V)$	863.981407	1.628510	± 60
$T_{min}(^{\circ}C)$	10	$V_{min}(V)$	863.981805	2.089169	± 60
$T_{max}(^{\circ}C)$	60	$V_{min}(V)$	863.981613	1.866941	± 60

FREQUENCY	CH38	TEST MODE	C
------------------	------	------------------	---

TEST CONDITION			Carrier Frequency (MHz)	Frequency Drift (ppm)	Limit (ppm)
$T_{nom}(^{\circ}C)$	20	$V_{nom}(V)$	864.933381	3.980987	± 60
$T_{min}(^{\circ}C)$	10	$V_{min}(V)$	864.933794	4.386482	± 60
$T_{max}(^{\circ}C)$	60	$V_{min}(V)$	864.933611	4.174442	± 60

4.2. CARRIER POWER

4.2.1. LIMIT OF CARRIER POWER

EQUIPMENT	MAXIMUM e.r.p.	FREQUENCY BAND
Cordless Audio	10mW	863MHz to 865MHz
In-ear Monitoring	10mW	
In-vehicle Cordless	2mW	
Personal Cordless	1mW	
Consumer Radiomicrophones	10mW	
NOTE: Power limitations for applications in other bands are subject to CEPT/ERC/REC 70-03 [i.2]. European or national legislation.		

4.2.2. TEST PROCEDURES

Reference to ETSI EN 301 357-1 V1.4.1 clause 8.4.2.

4.2.3. DEVIATION FROM TEST STANDARD

No deviation.

4.2.4. TEST SETUP

For the actual test configuration, please refer to the related item in this test report (Photographs of the Test Configuration).

4.2.5. TEST RESULTS

TEST MDOE B				
TEST CONDITION		POWER (dBm)		
		CHANNEL1 863.08MHz	CHANNEL19 863.98MHz	CHANNEL38 864.93MHz
T_{nom} 20°C	$V_{nom}(V)$	8.46	8.46	8.78
T_{min} 0°C	$V_{min}(V)$	8.12	8.23	8.51
	$V_{max}(V)$	8.15	8.26	8.54
T_{max} 50°C	$V_{min}(V)$	4.58	4.74	4.48
	$V_{max}(V)$	4.61	4.77	4.51

TEST MDOE C				
TEST CONDITION		POWER (dBm)		
		CHANNEL1 863.08MHz	CHANNEL19 863.98MHz	CHANNEL38 864.93MHz
T_{nom} 20°C	$V_{nom}(V)$	6.95	6.91	6.66
T_{min} -10°C	$V_{min}(V)$	8.99	9.47	9.52
T_{max} 60°C	$V_{min}(V)$	1.81	1.67	1.50

4.3. CHANNEL BANDWIDTH

4.3.1. LIMIT OF CHANNEL BANDWIDTH

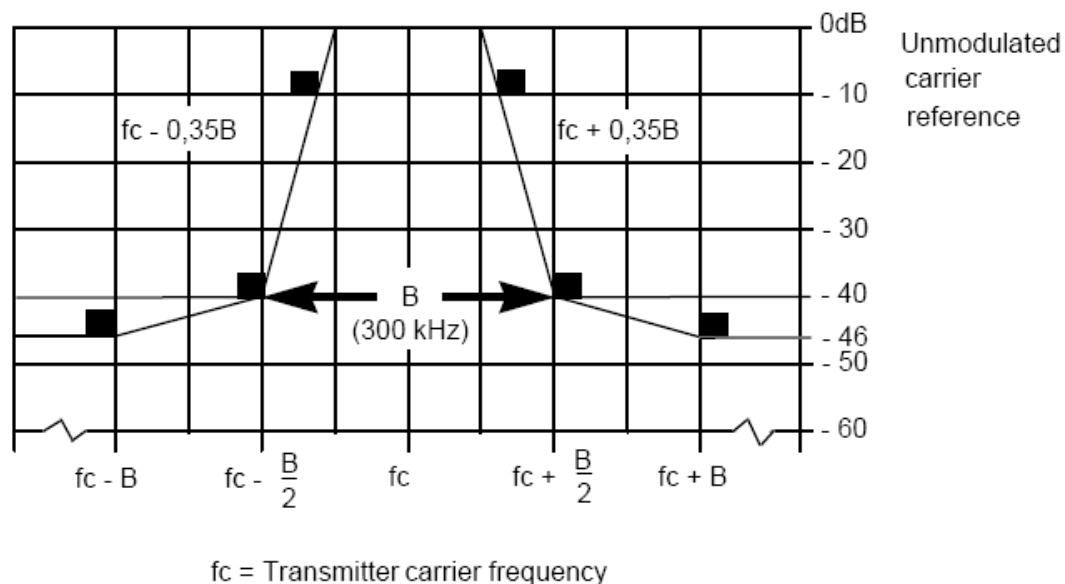

4.3.2. TEST PROCEDURES

Reference to ETSI EN 301 357-1 V1.4.1 clause 8.5.2.

4.3.3. DEVIATION FROM TEST STANDARD

No deviation.

4.3.4. TEST SETUP

For the actual test configuration, please refer to the related item in this test report (Photographs of the Test Configuration).

4.3.5. TEST RESULTS

TEST MODE B

CH 1 207V & 0°C

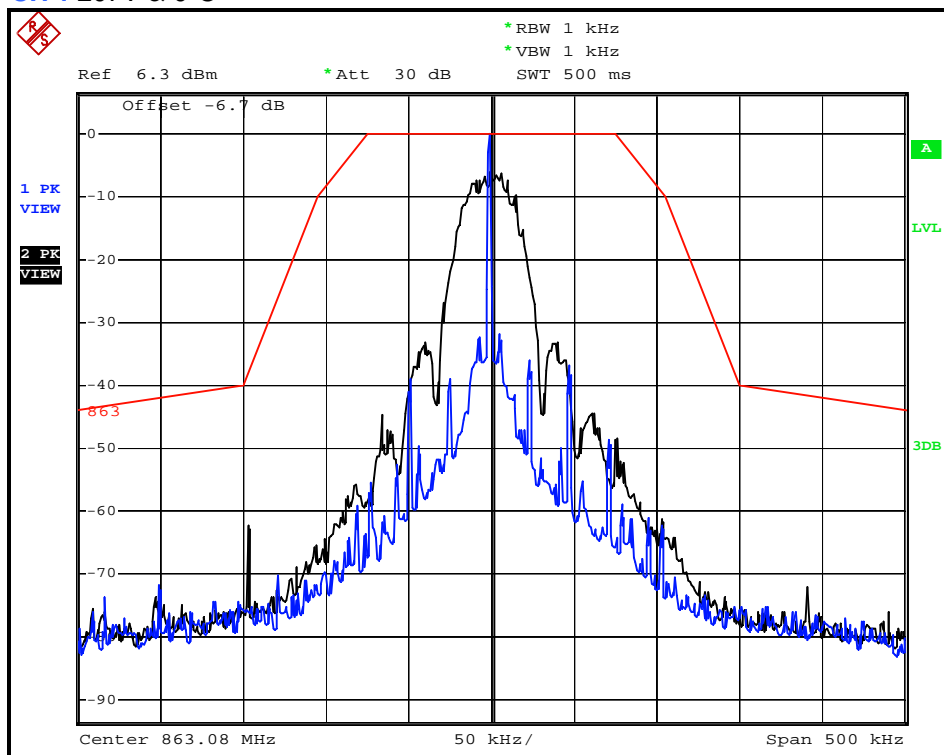

CH 19 207V & 0°C

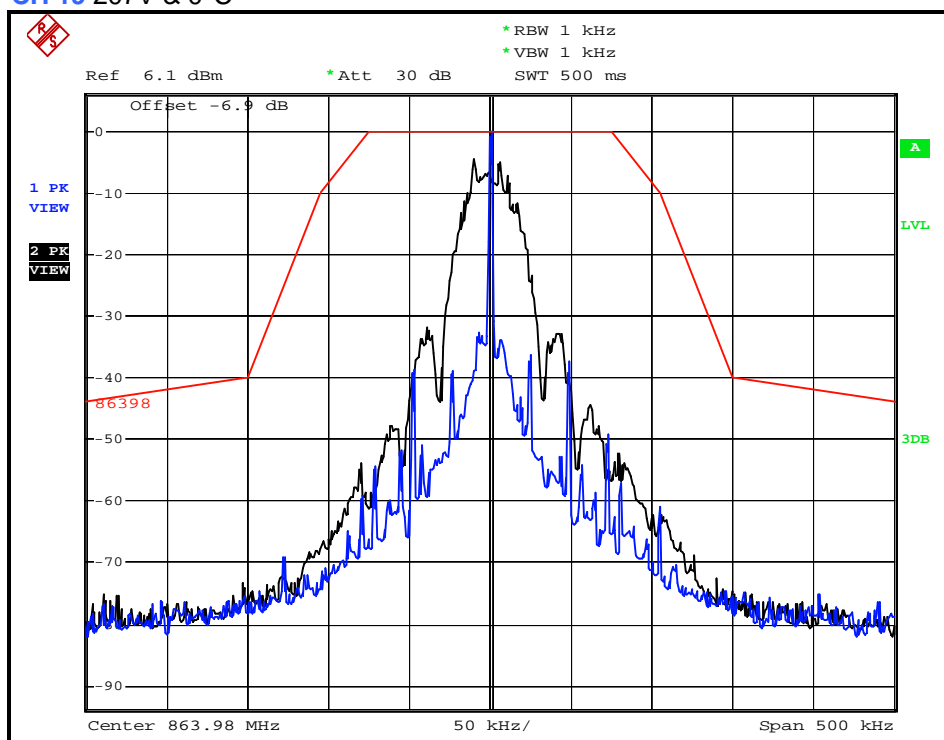



A D T

CH 38 207V & 0°C

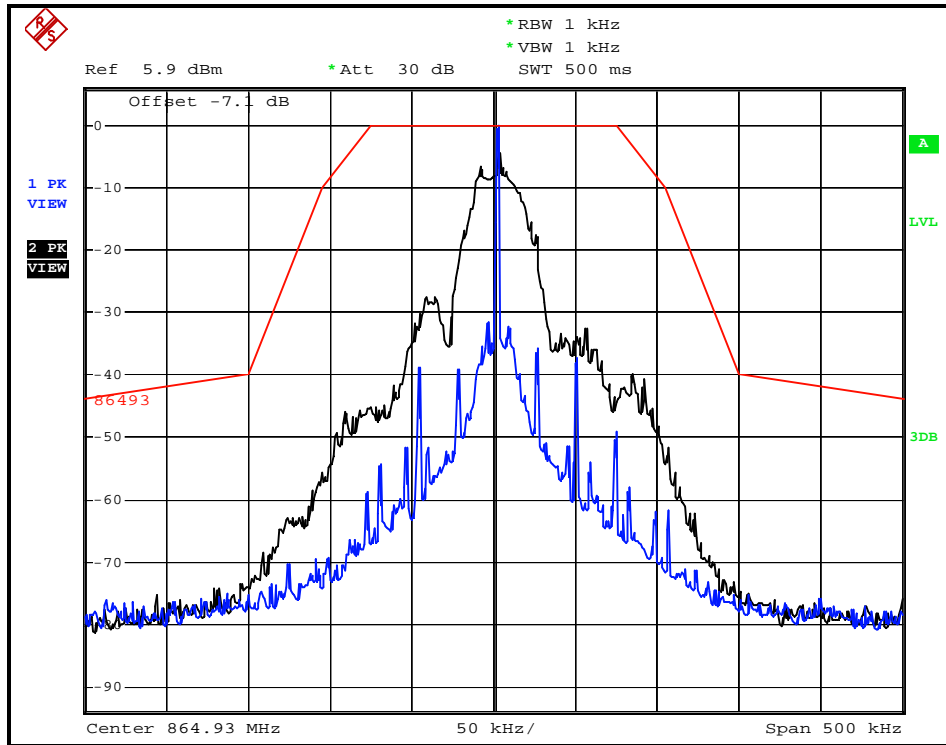

CH 1 207V & 20°C

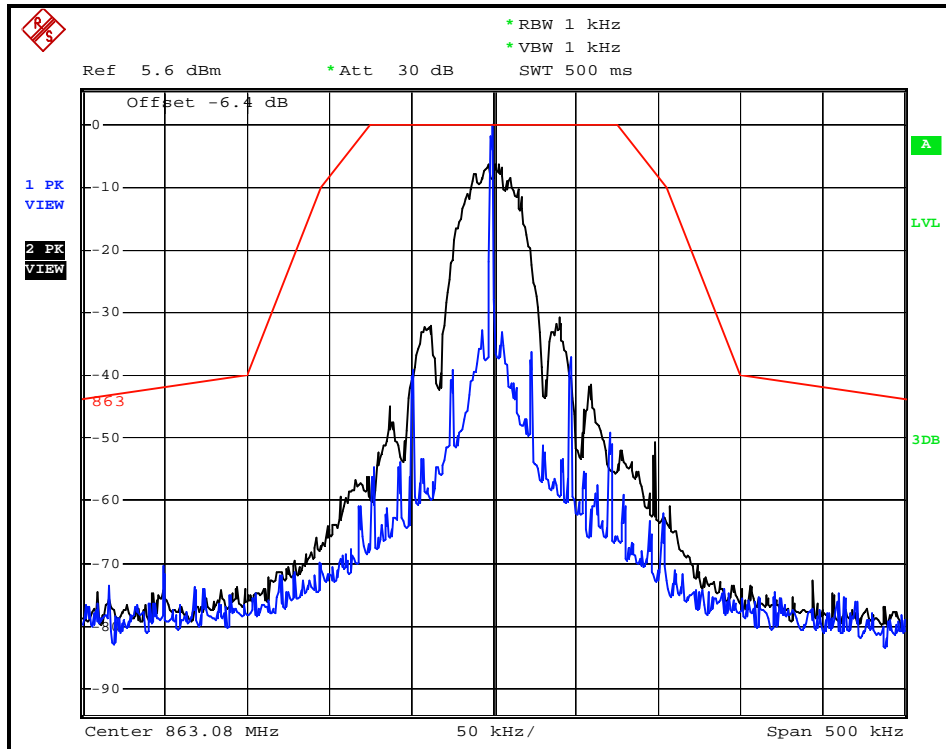



A D T

CH 19 207V & 20°C

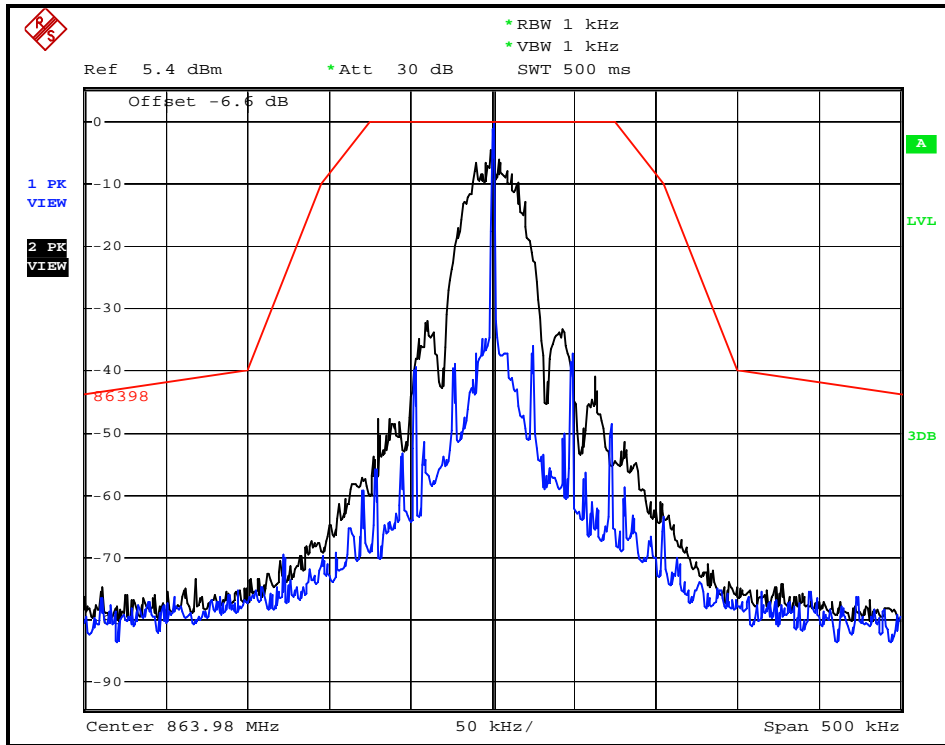

CH 38 207V & 20°C

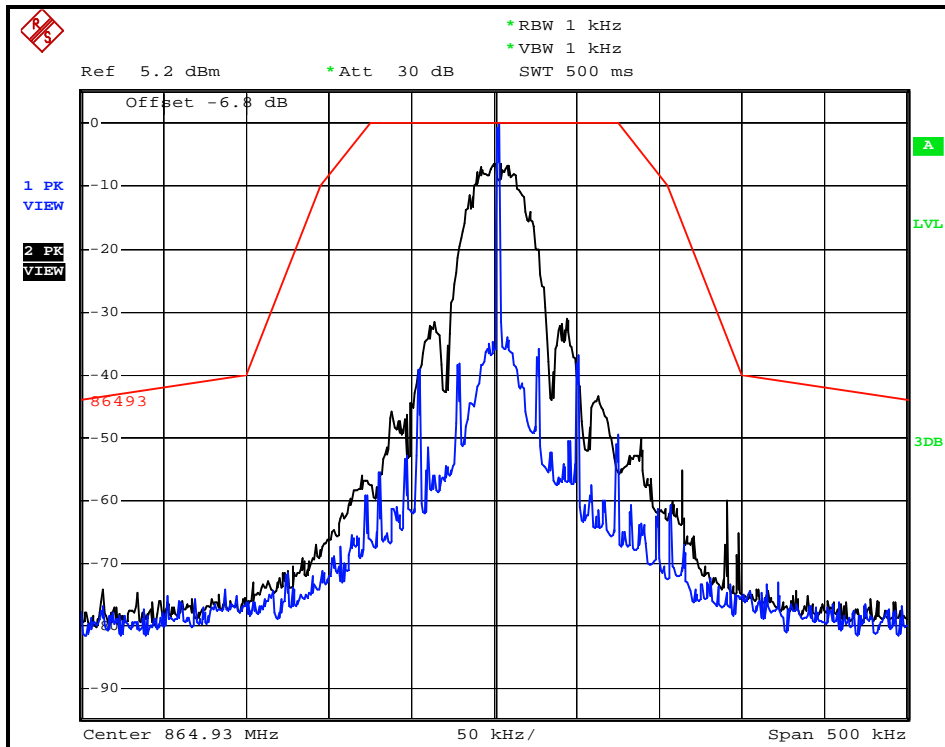



A D T

CH 1 207V & 50°C

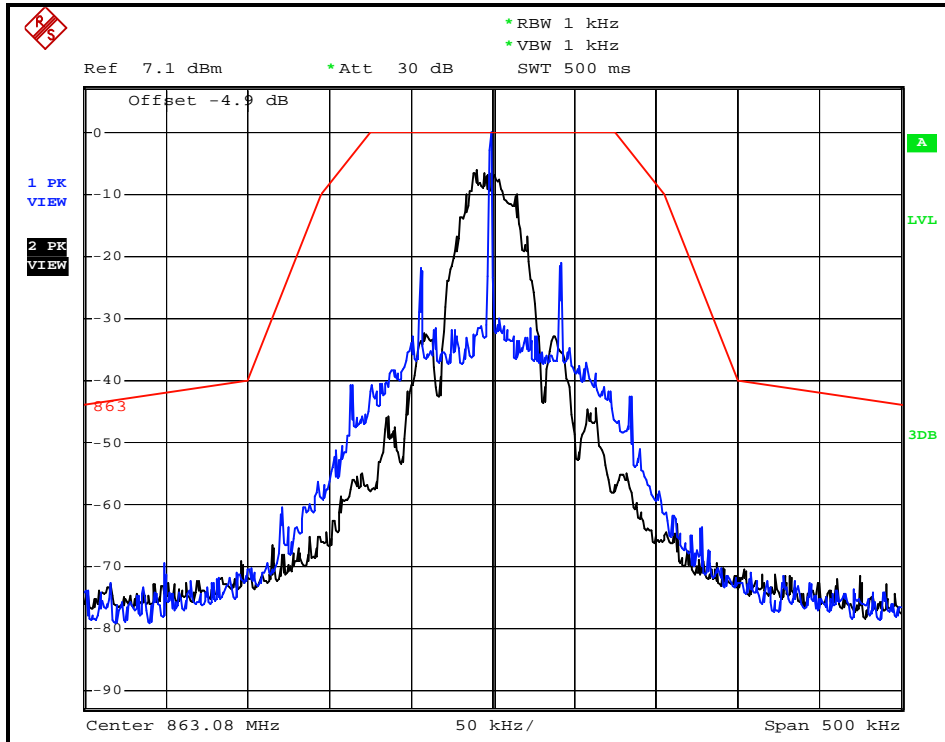

CH 19 207V & 50°C

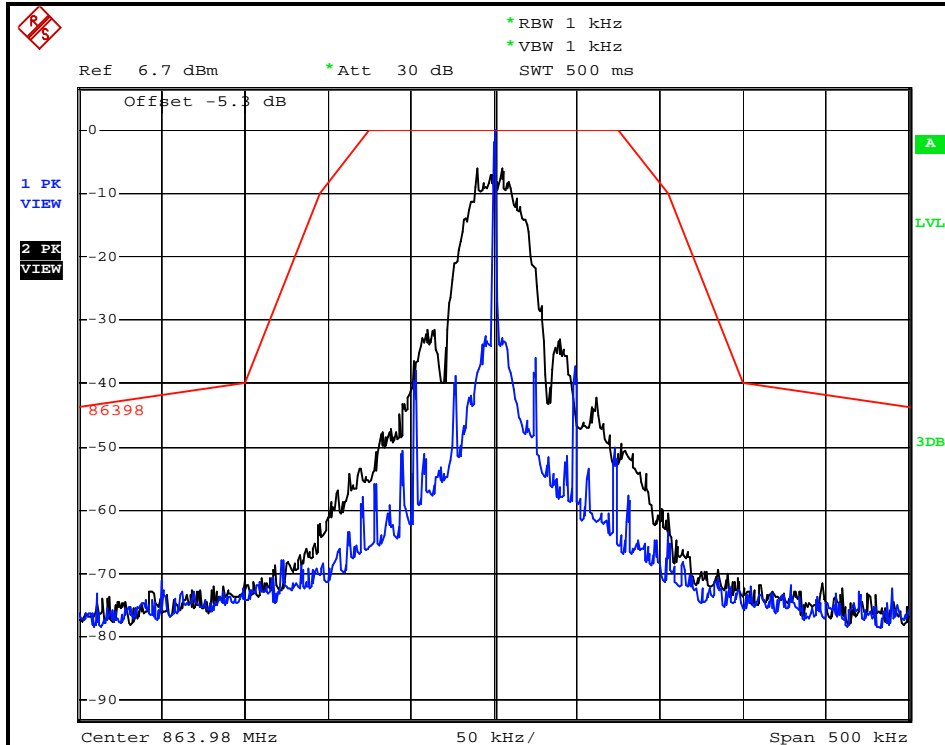



A D T

CH 38 207V & 50°C

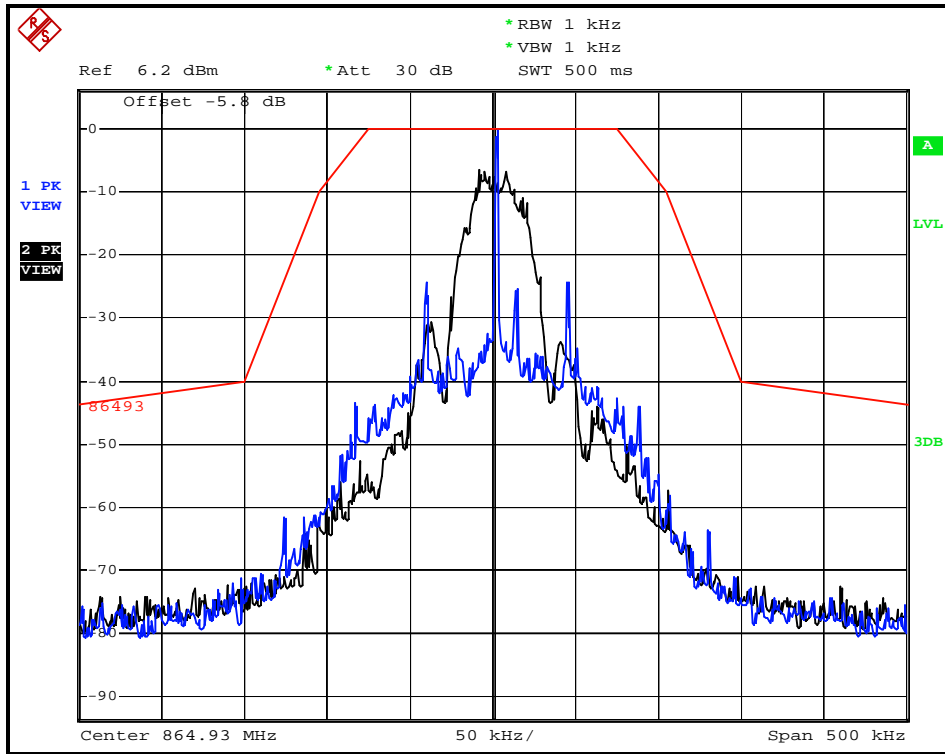

CH 1 230V & 0°C

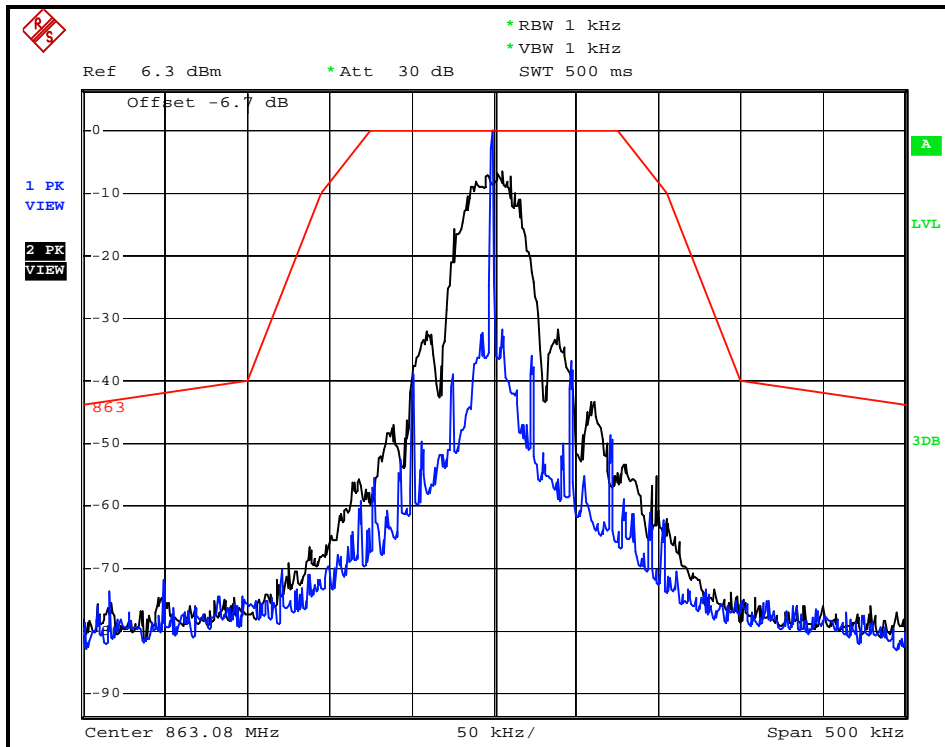



A D T

CH 19 230V & 0°C

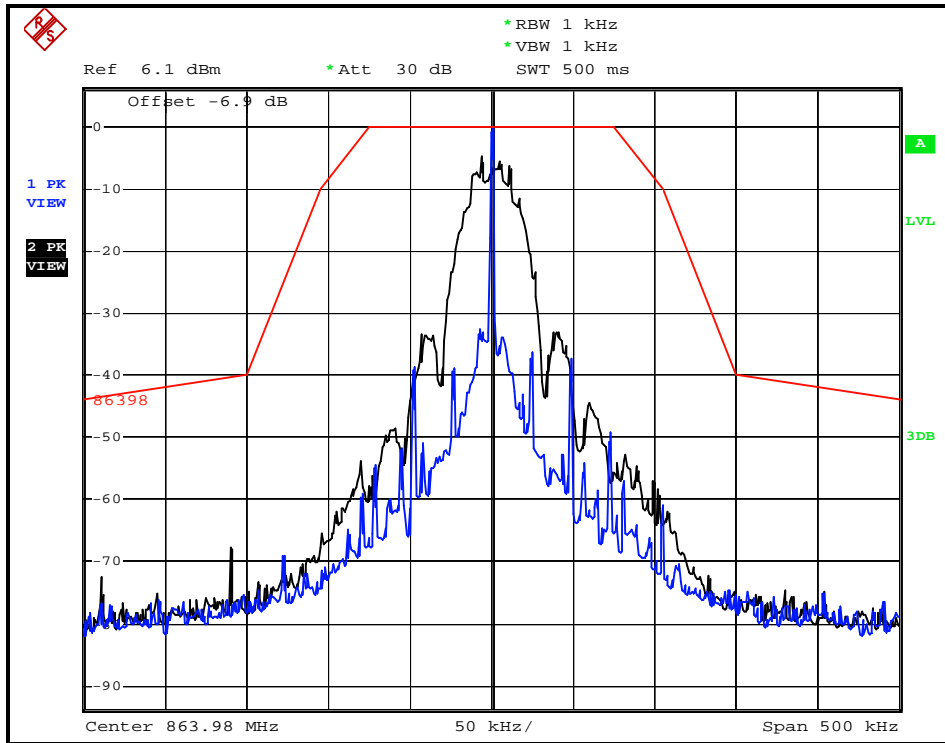

CH 38 230V & 0°C

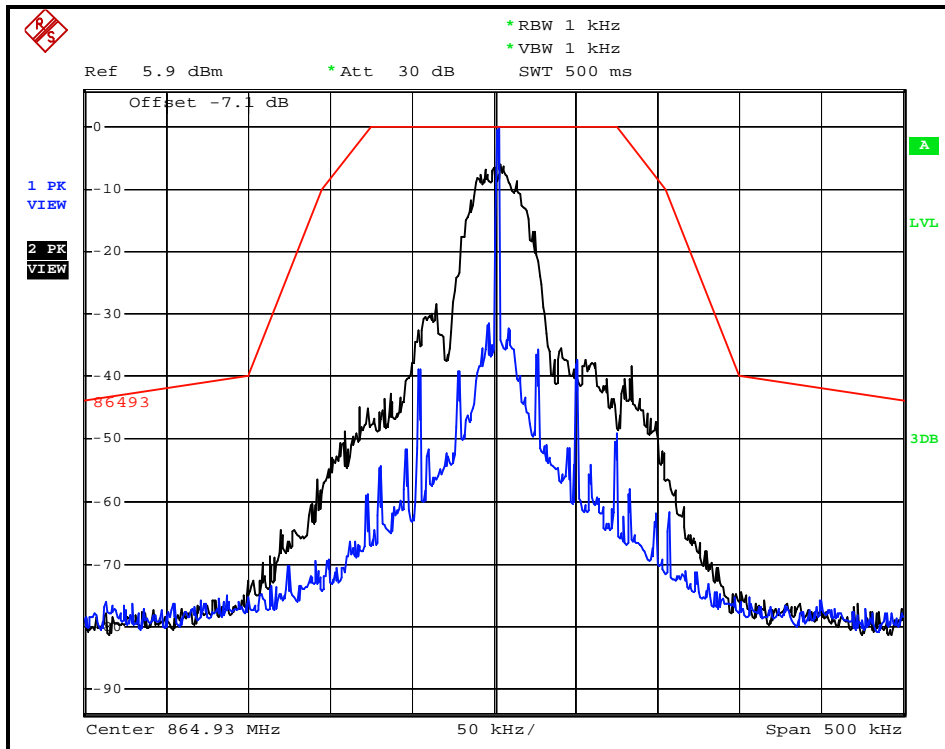



A D T

CH 1 230V & 20°C

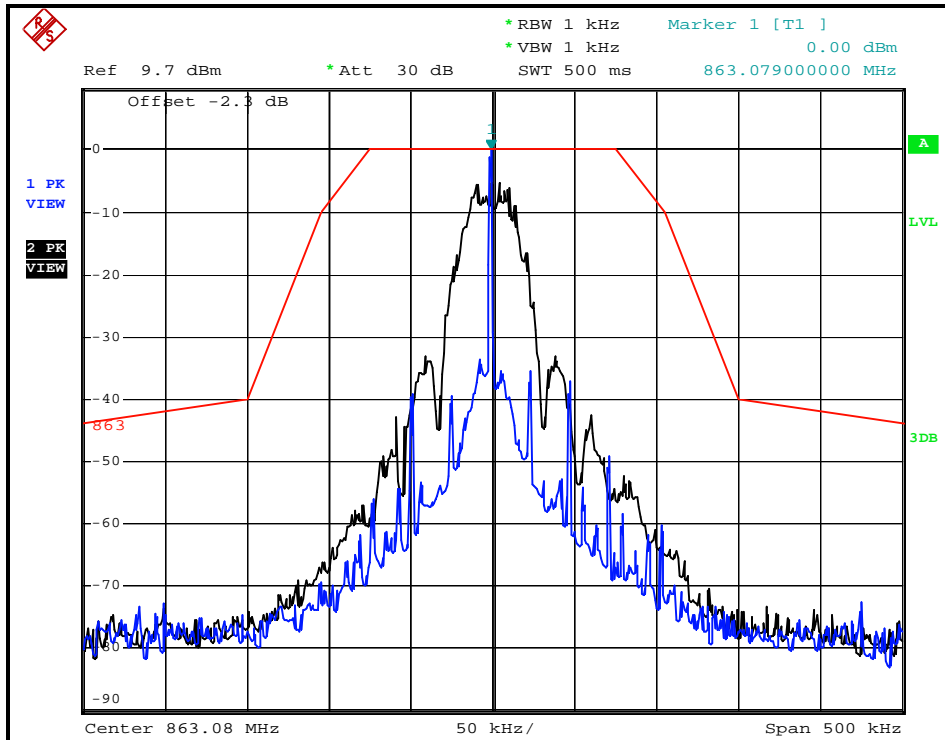

CH 19 230V & 20°C

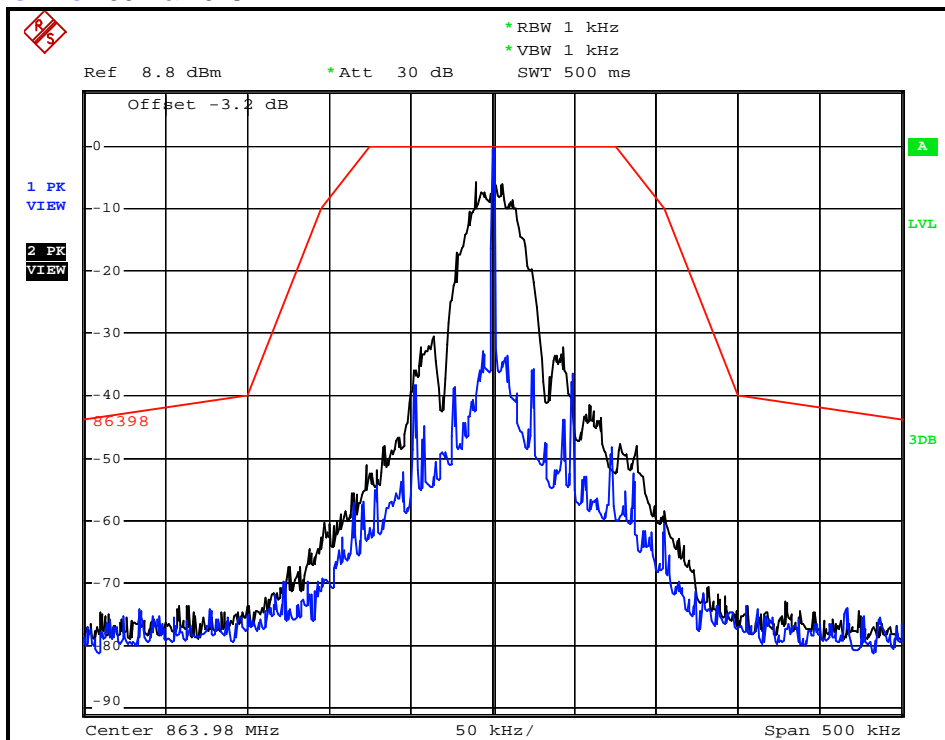



A D T

CH 38 230V & 20°C

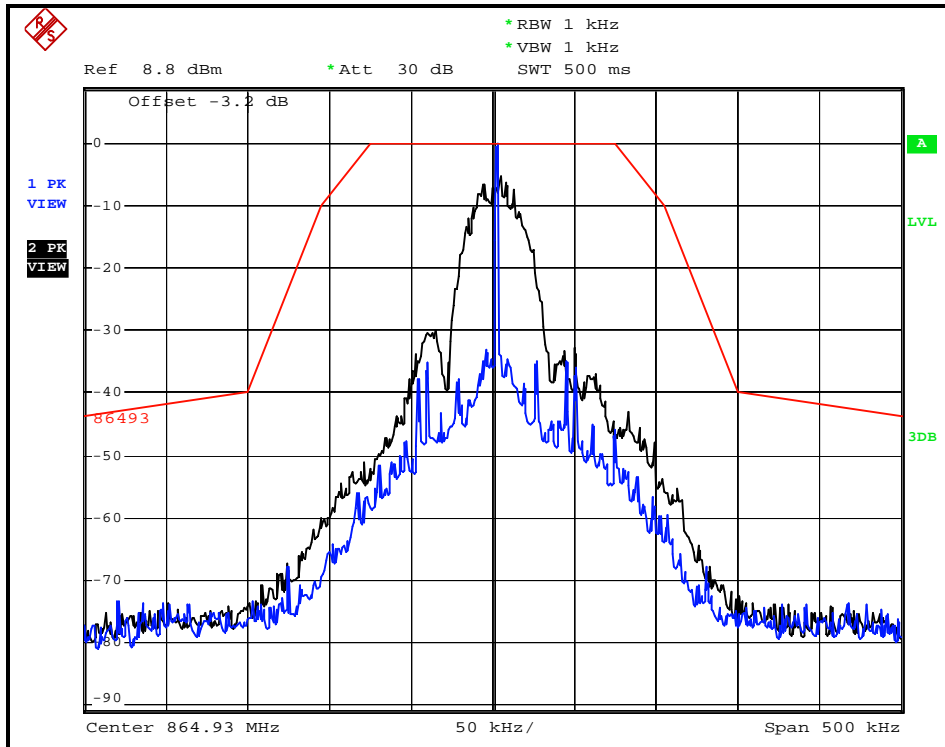

CH 1 230V & 50°C

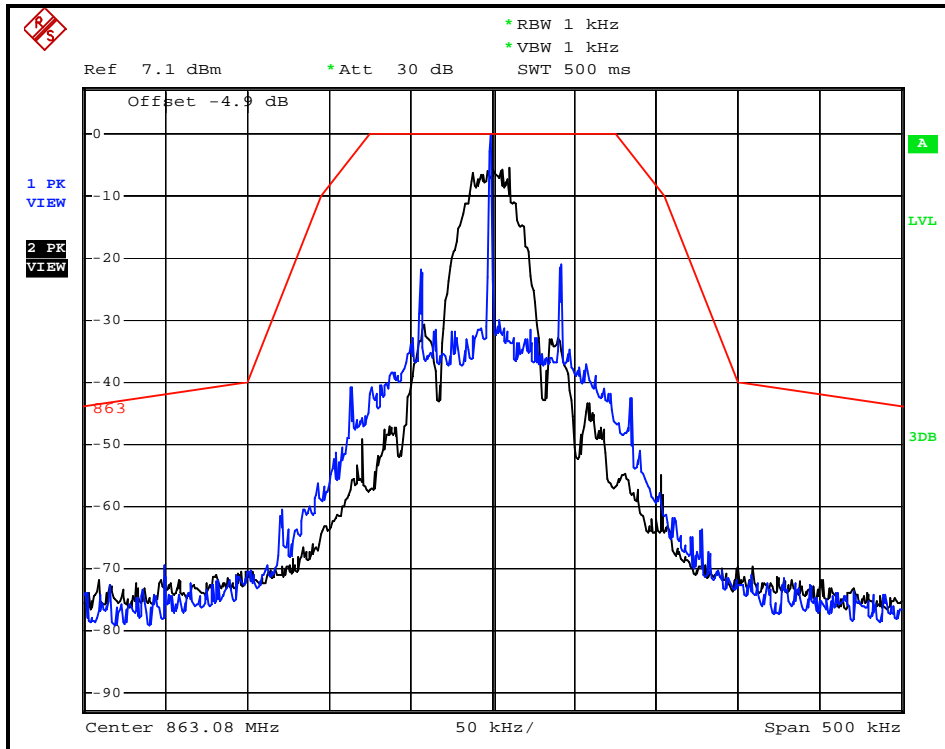



A D T

CH 19 230V & 50°C

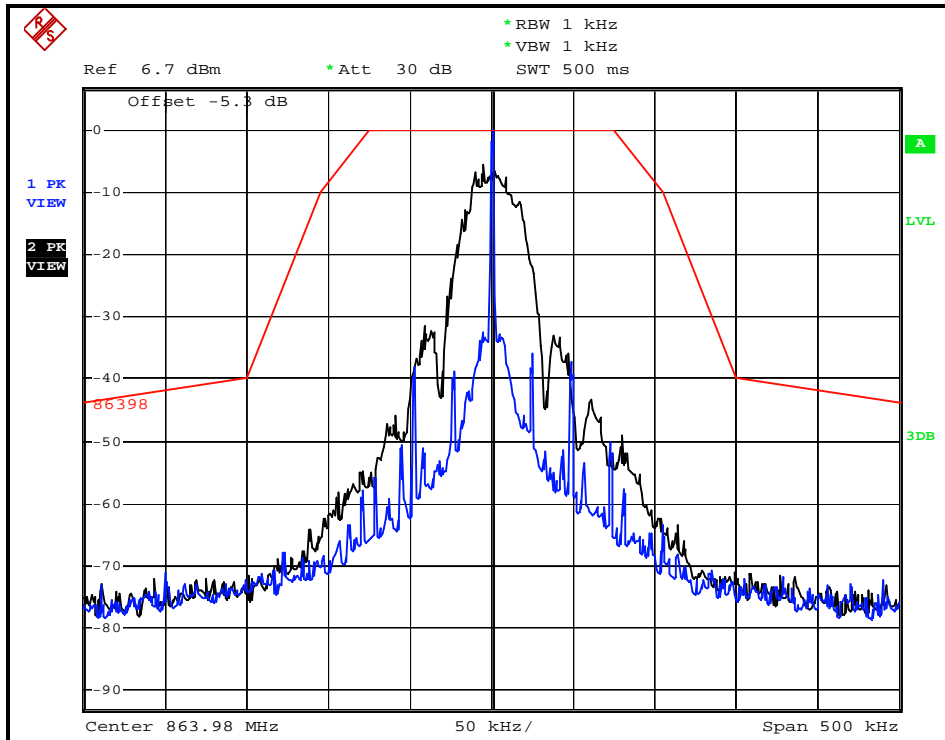

CH 38 230V & 50°C

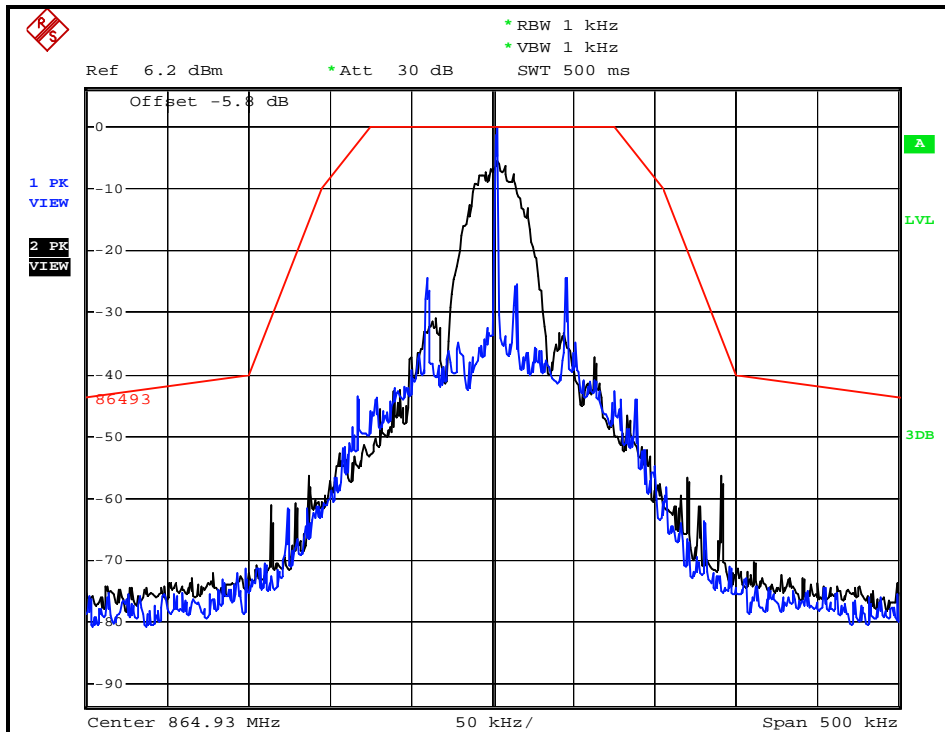



A D T

CH 1 253V & 0°C

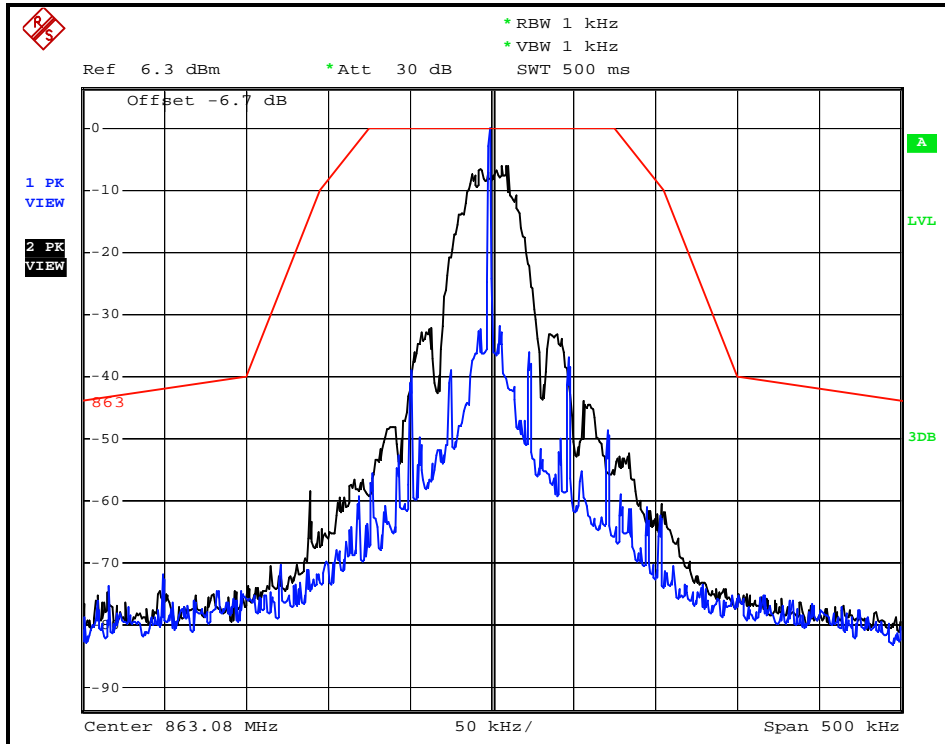

CH 19 253V & 0°C

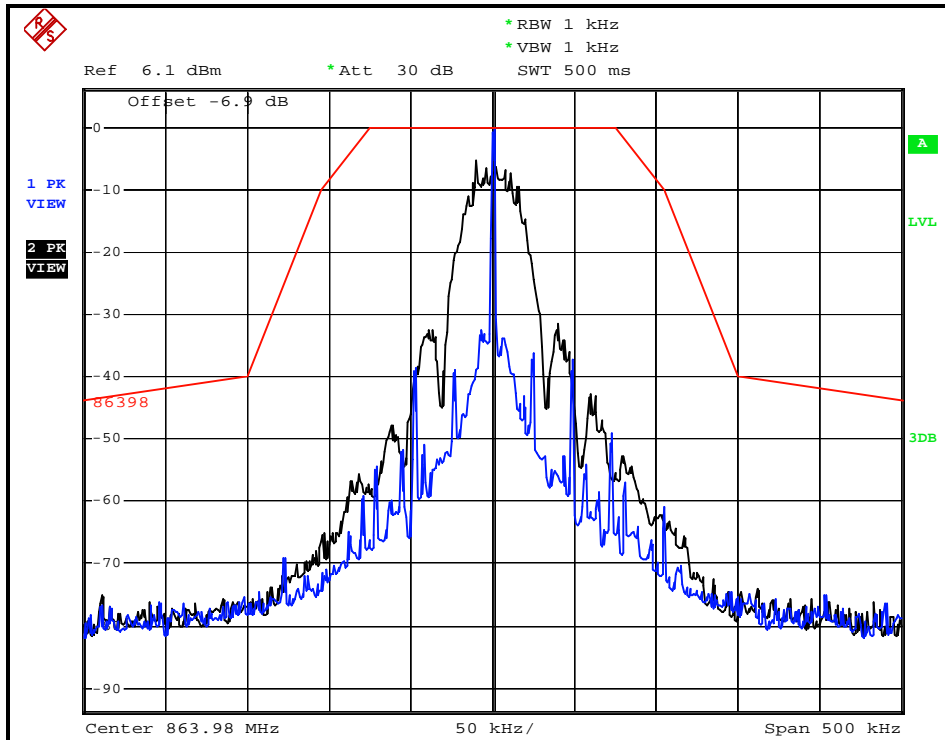



A D T

CH 38 253V & 0°C

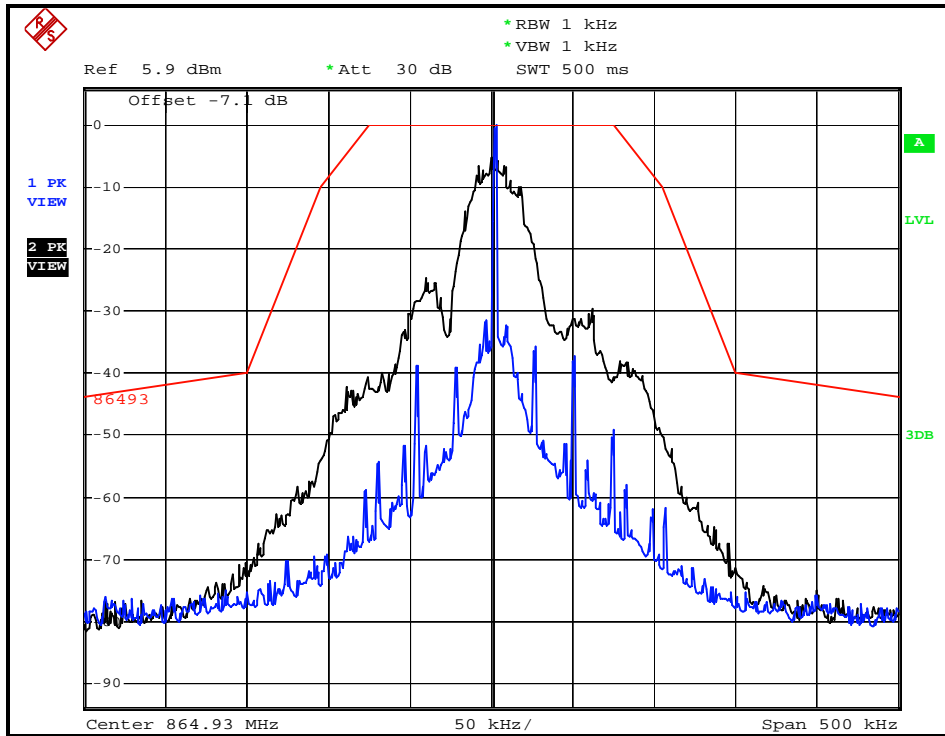

CH 1 253V & 20°C

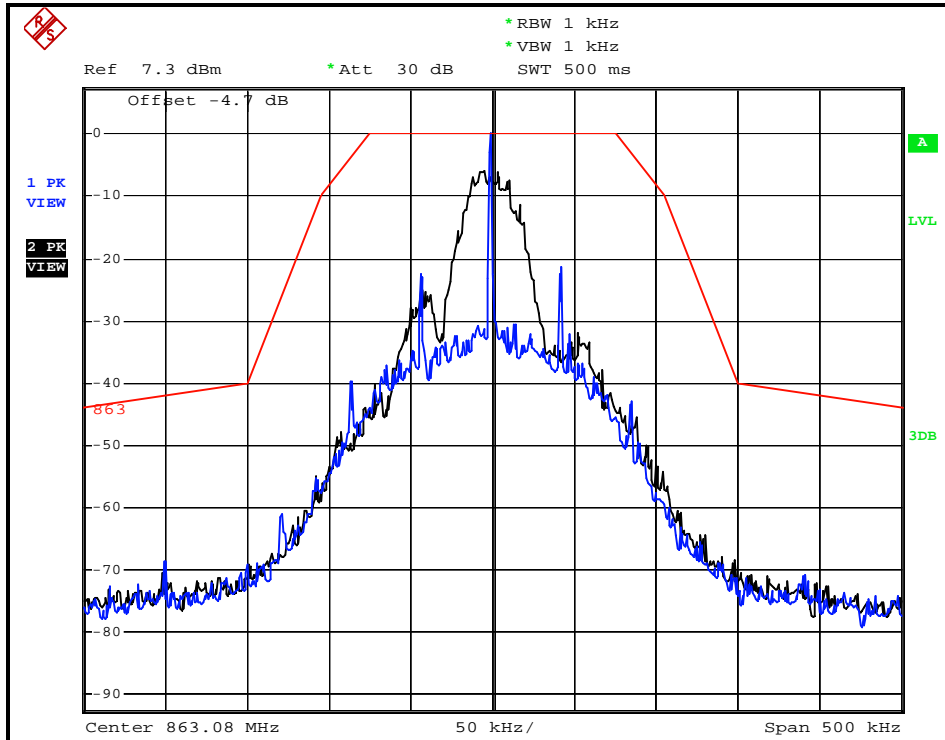



A D T

CH 19 253V & 20°C

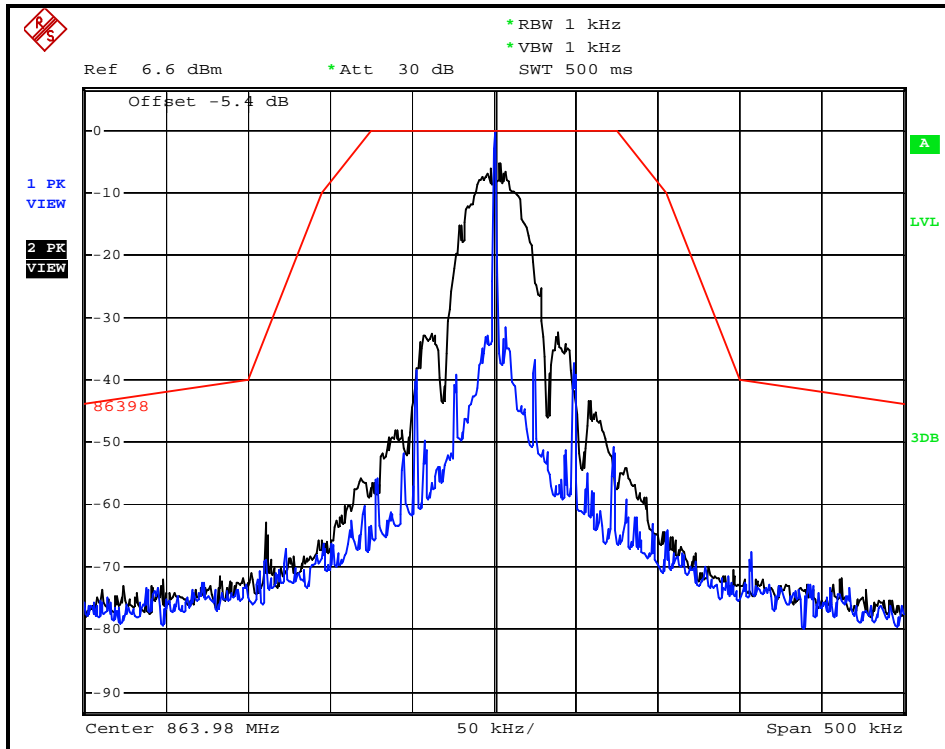

CH 38 253V & 20°C

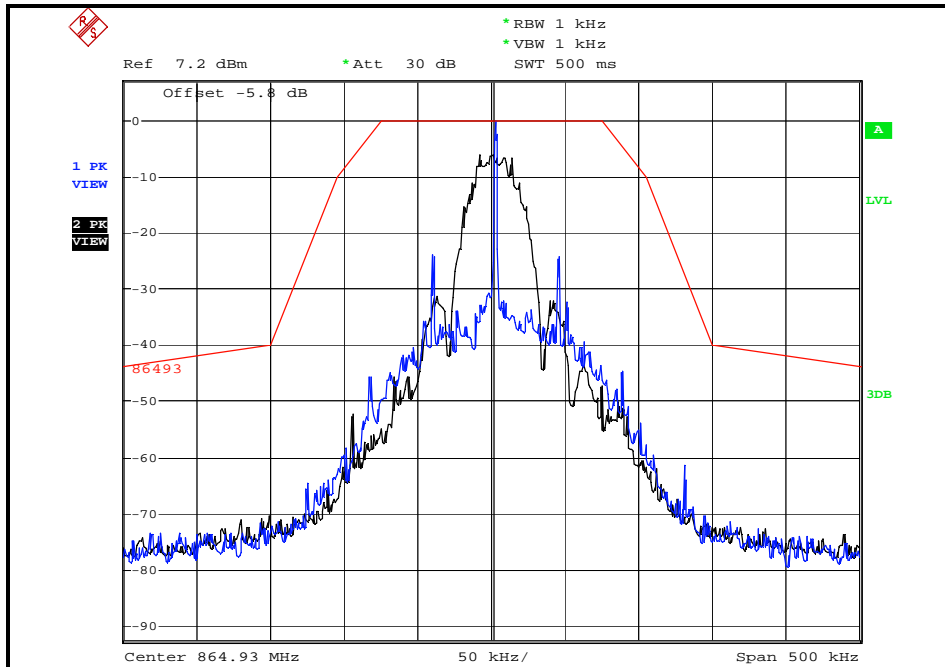



A D T

CH 1 253V & 50°C

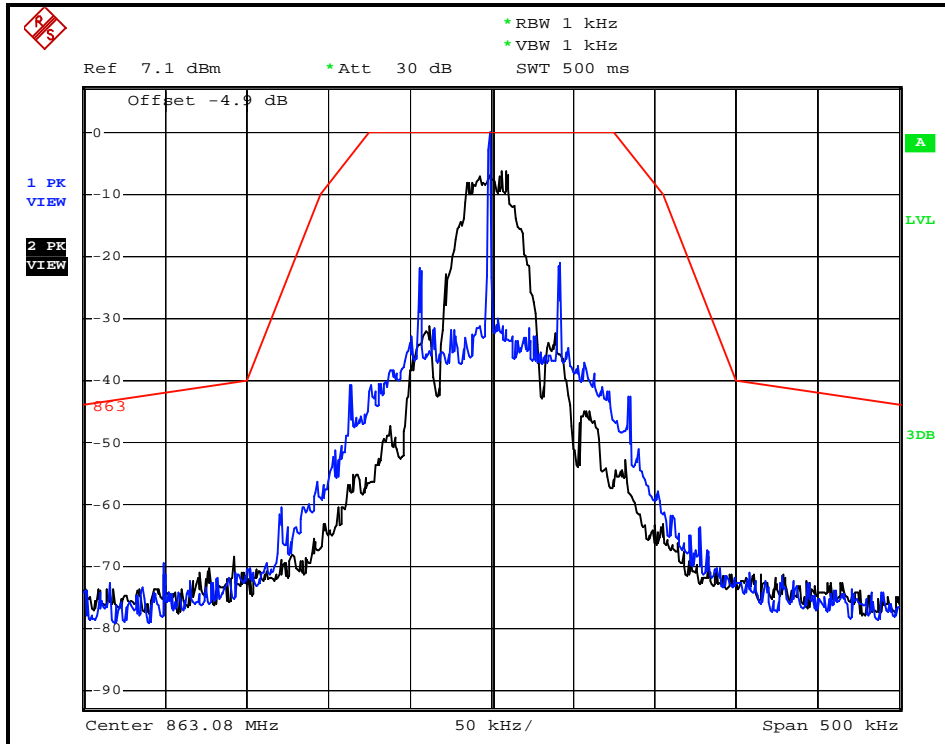

CH 19 253V & 50°C

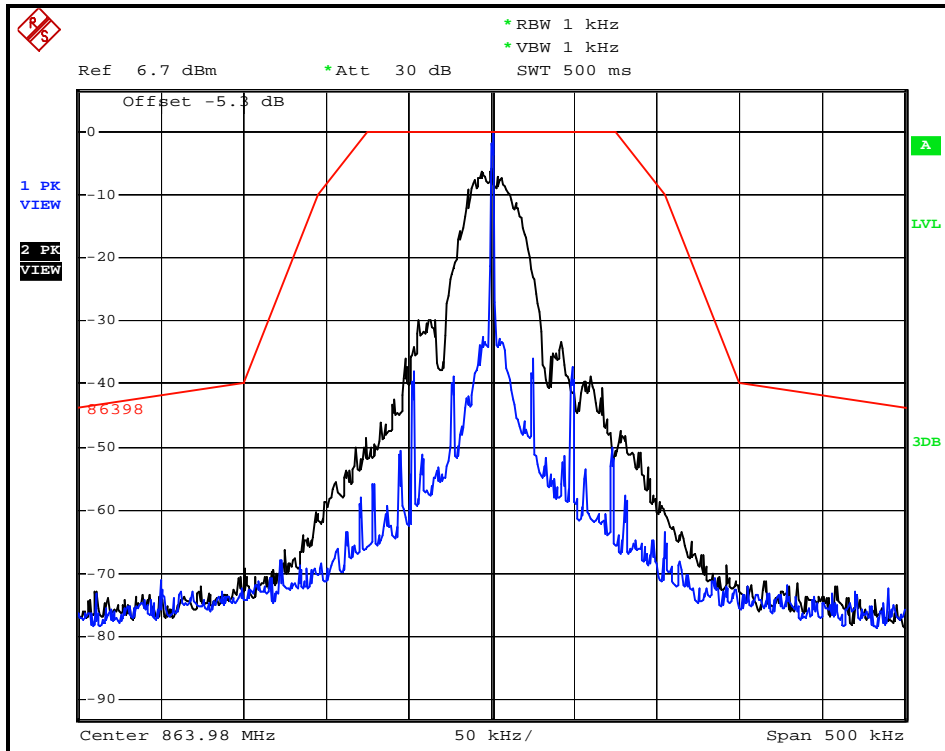



A D T

CH 38 253V & 50°C

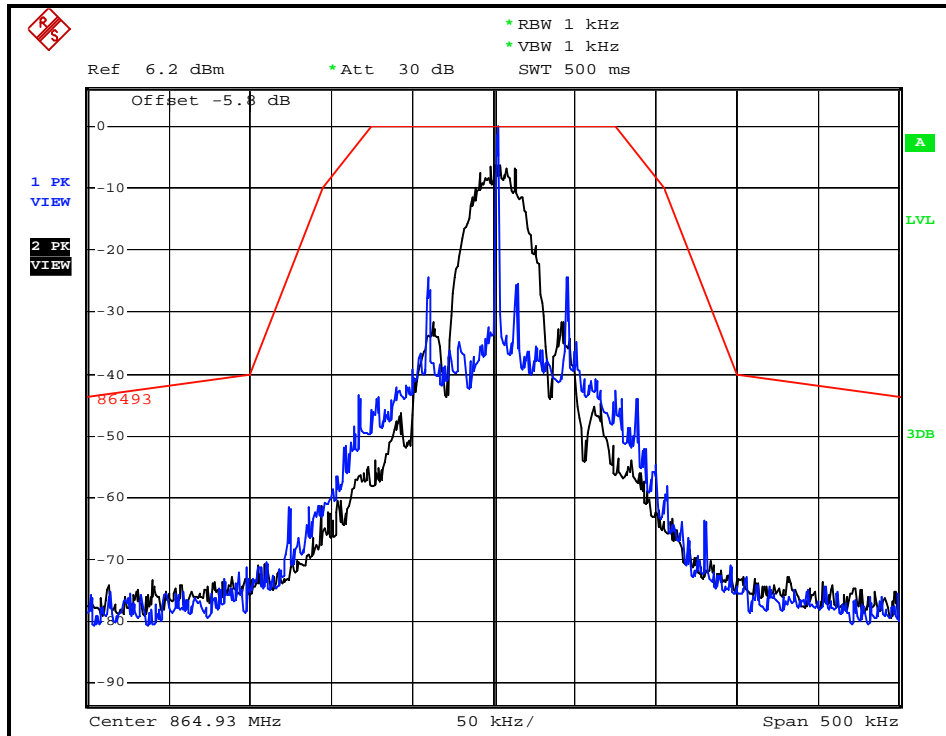

TEST MODE C

CH 1 3.1V & -10°C

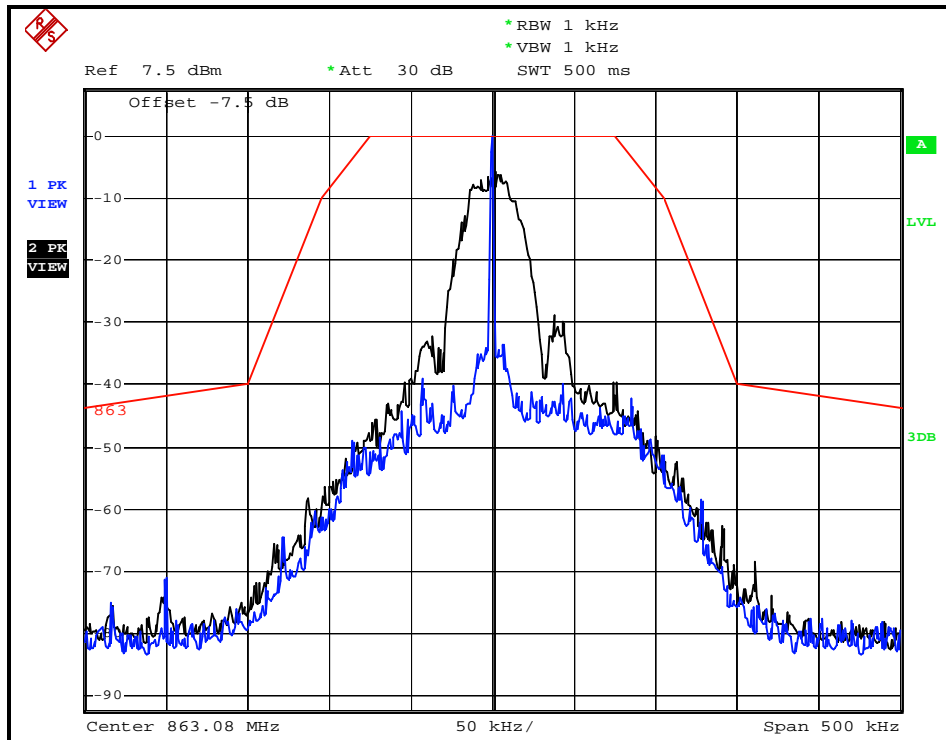



A D T

CH 19 3.1V & -10°C

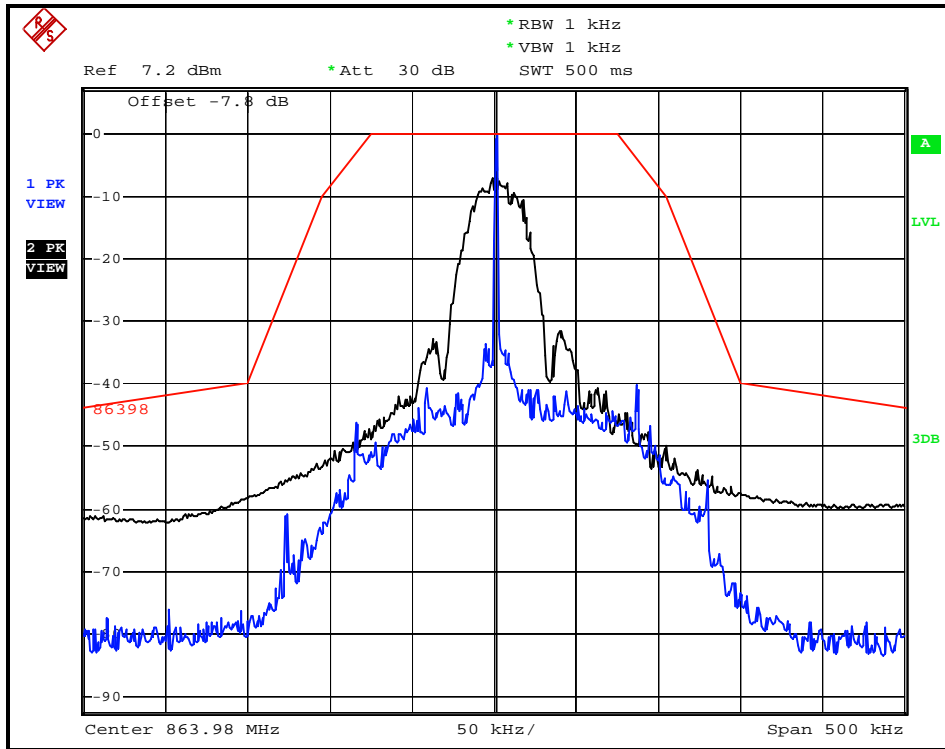

CH 38 3.1V & -10°C

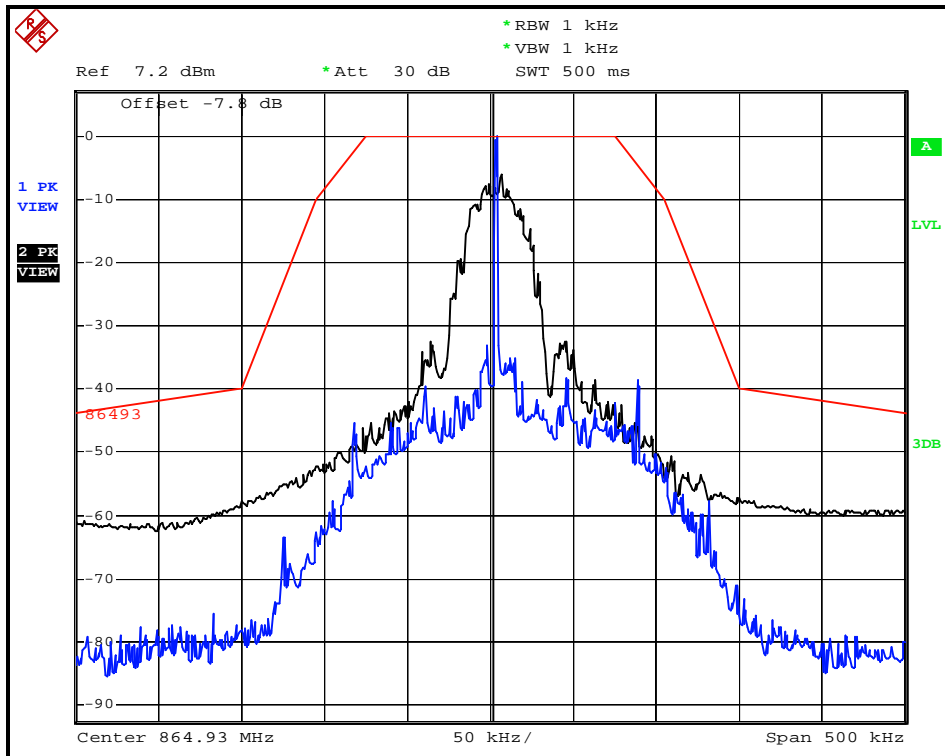



A D T

CH 1 3.1V & 20°C

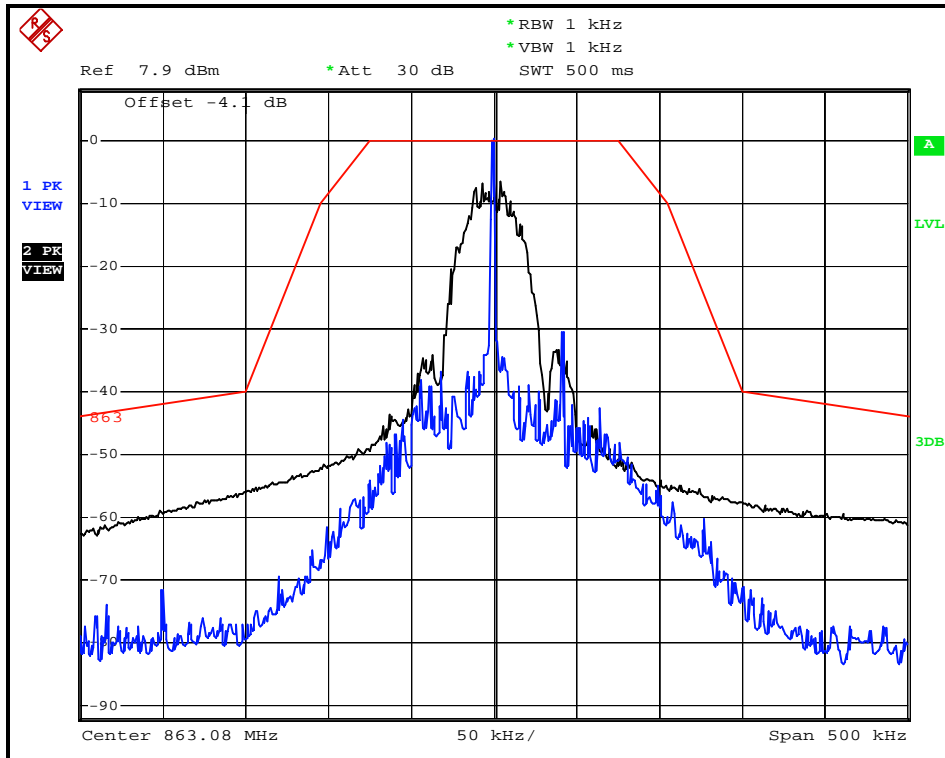

CH 19 3.1V & 20°C

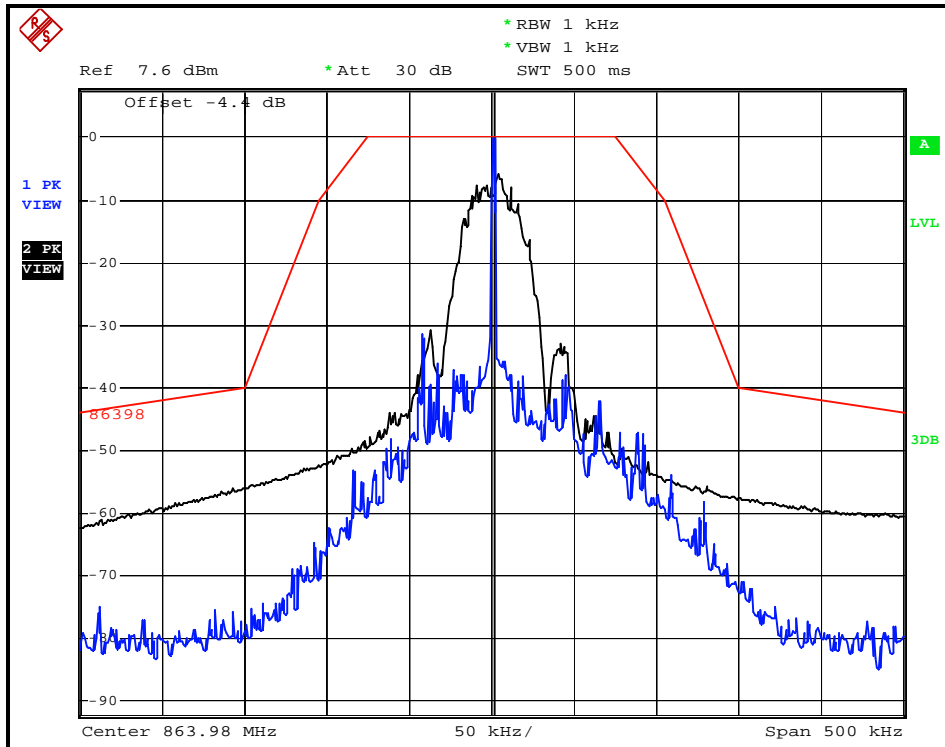



A D T

CH 38 3.1V & 20°C

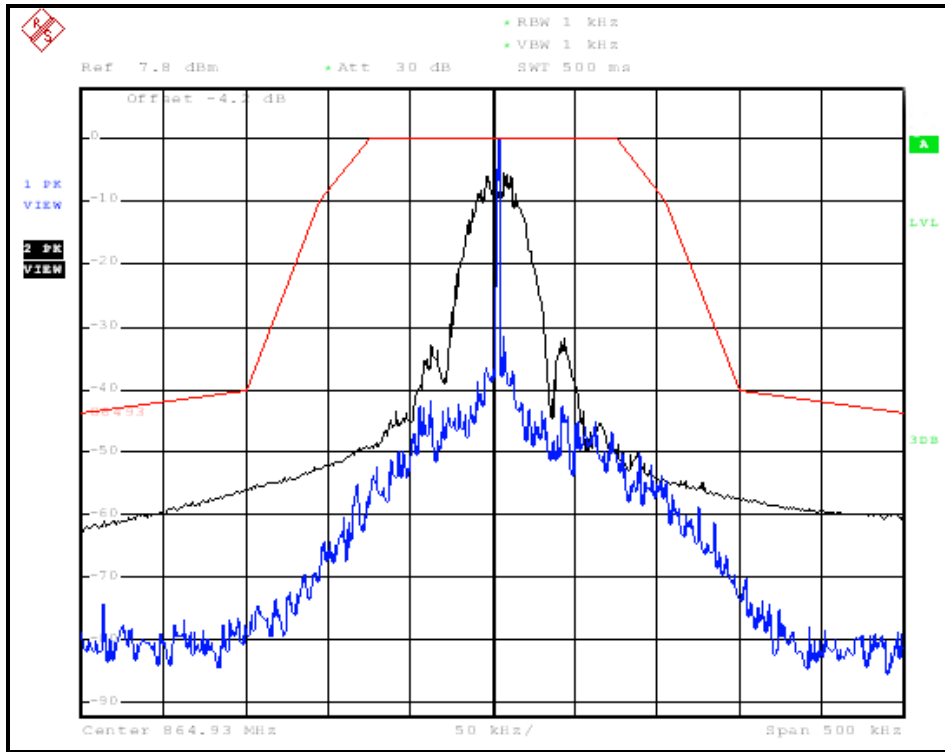

CH 1 3.1V & 60°C

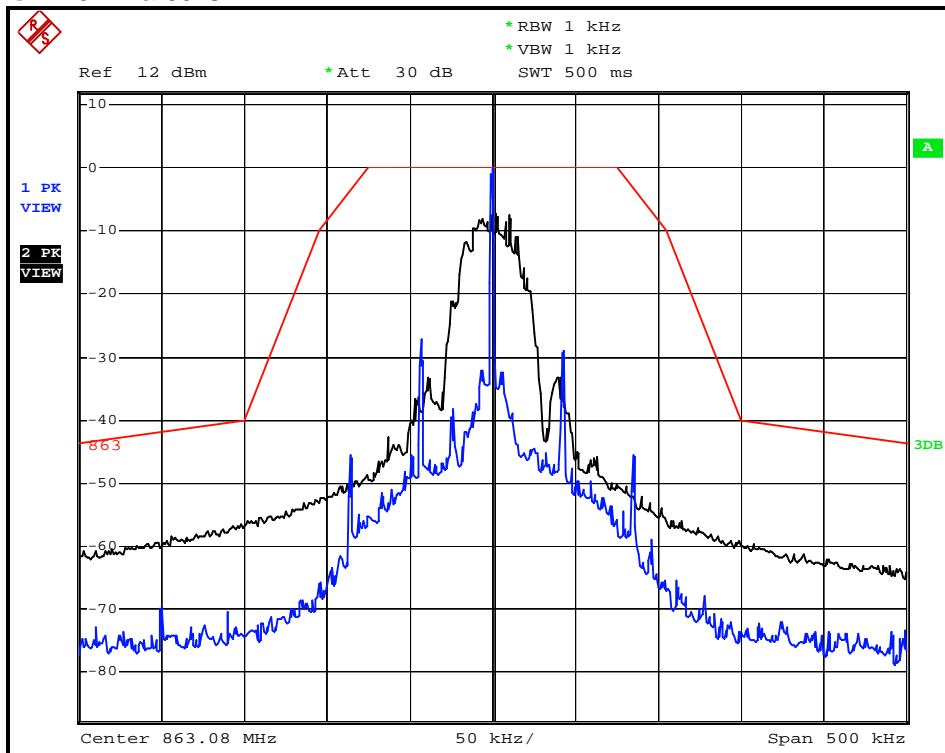



A D T

CH 19 3.1V & 60°C

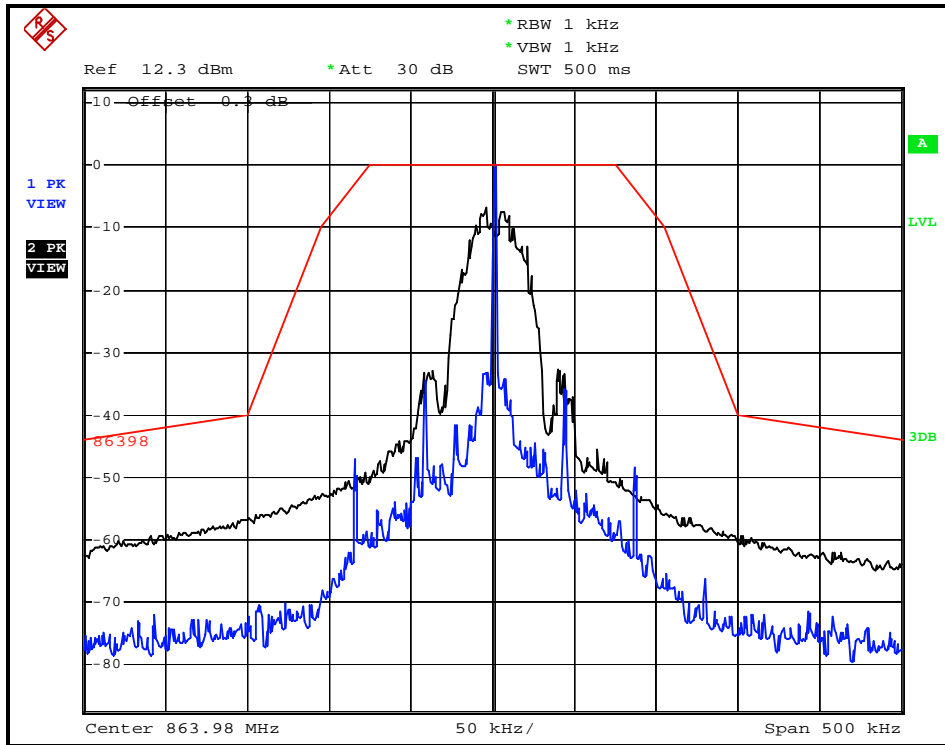

CH 38 3.1V & 60°C

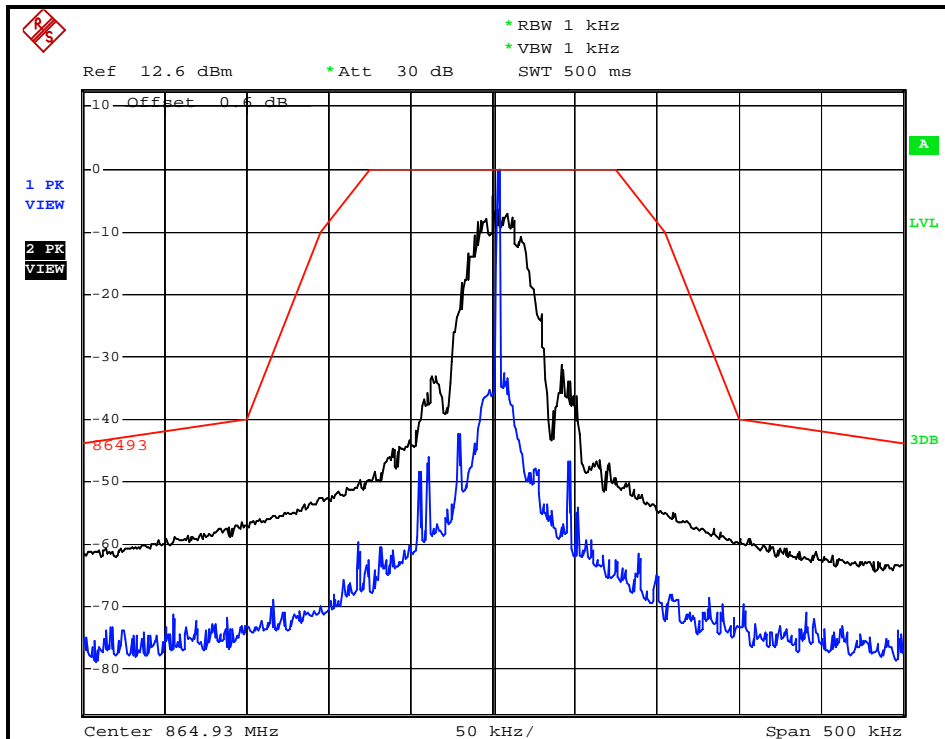



A D T

CH 1 3.7V & -10°C

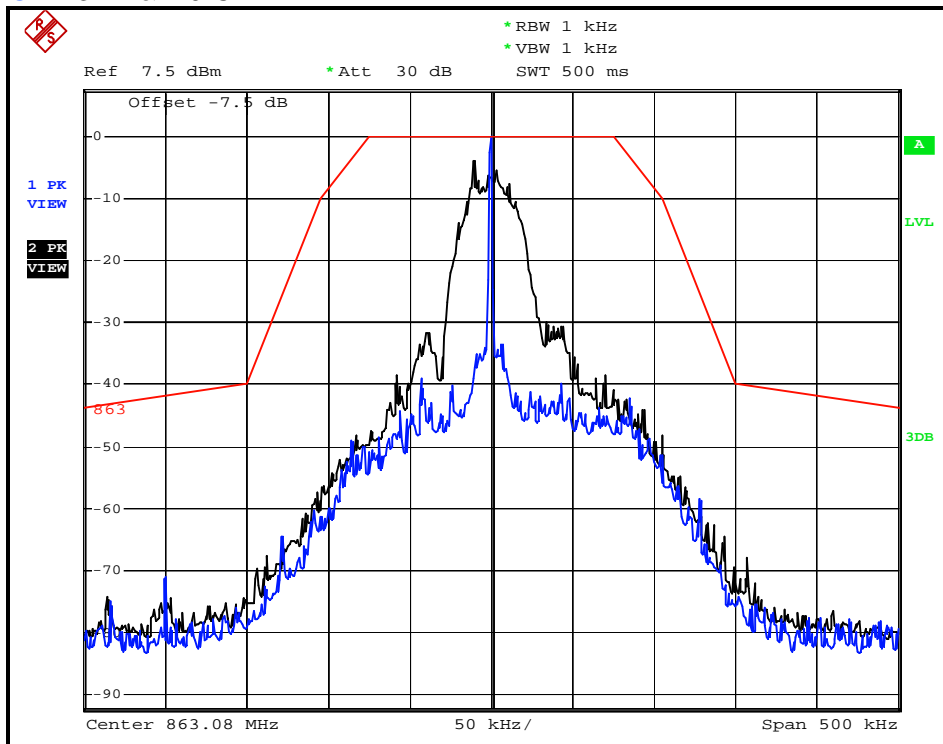

CH 19 3.7V & -10°C

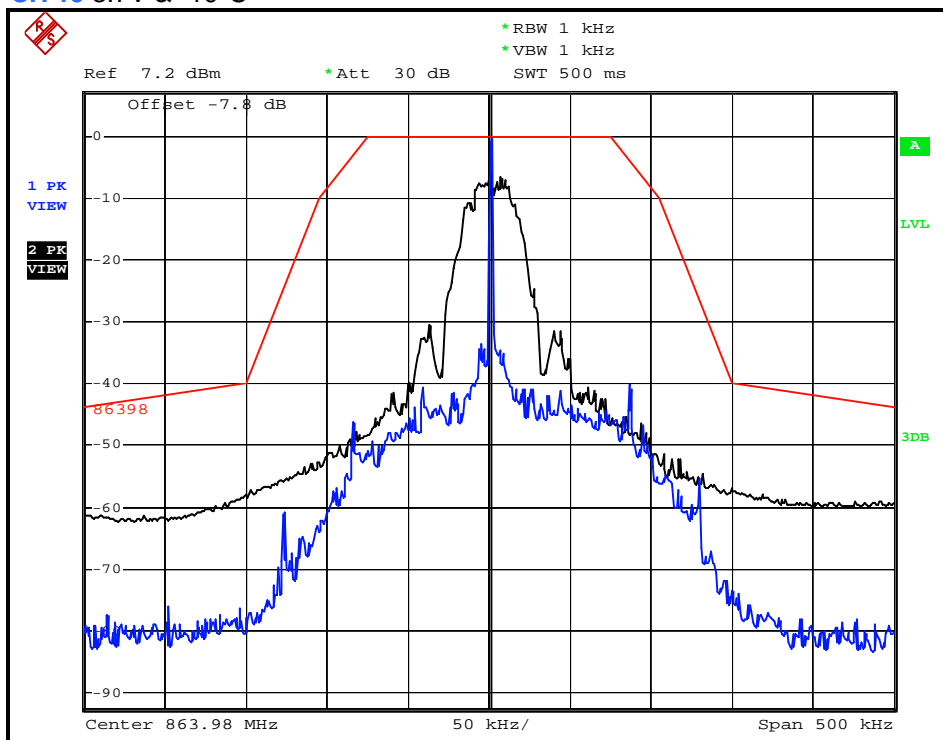



A D T

CH 38 3.7V & -10°C

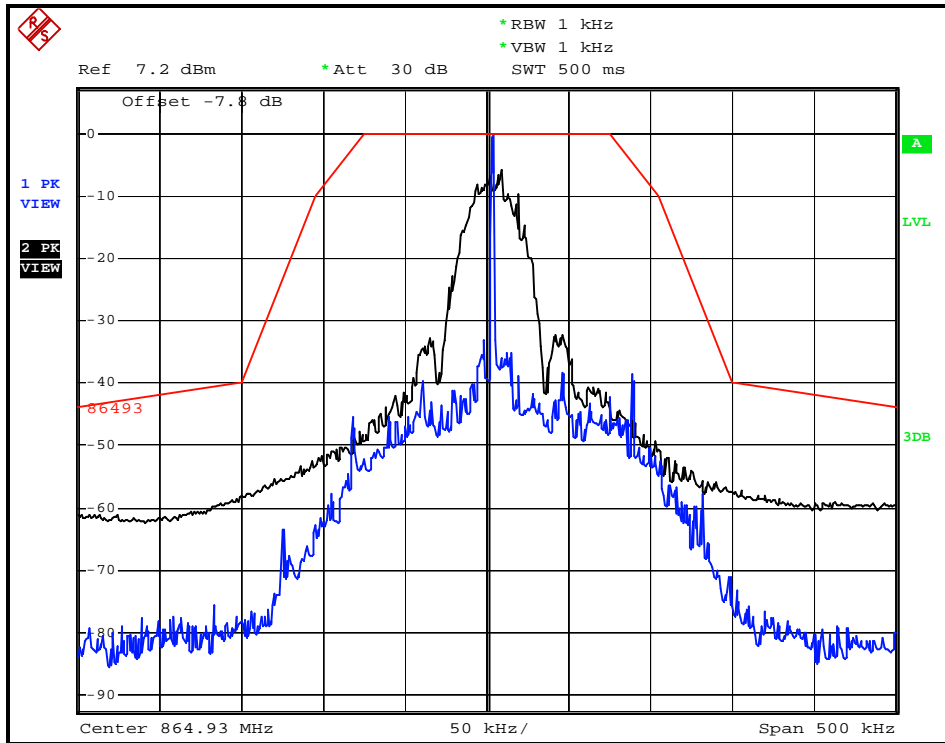

CH 1 3.7V & 20°C

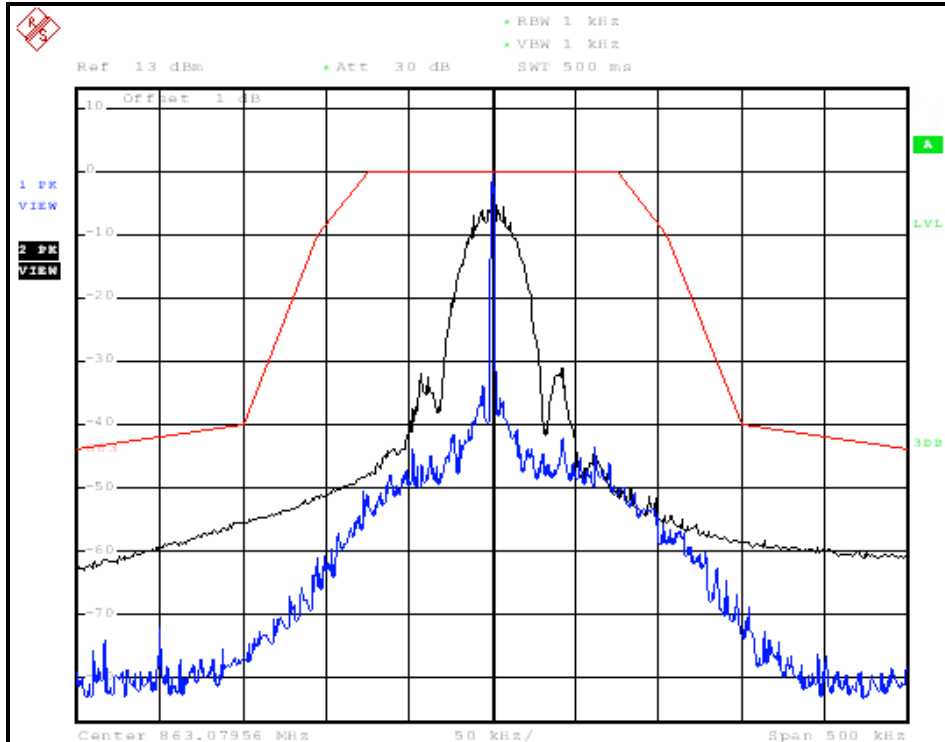



A D T

CH 19 3.7V & 20°C

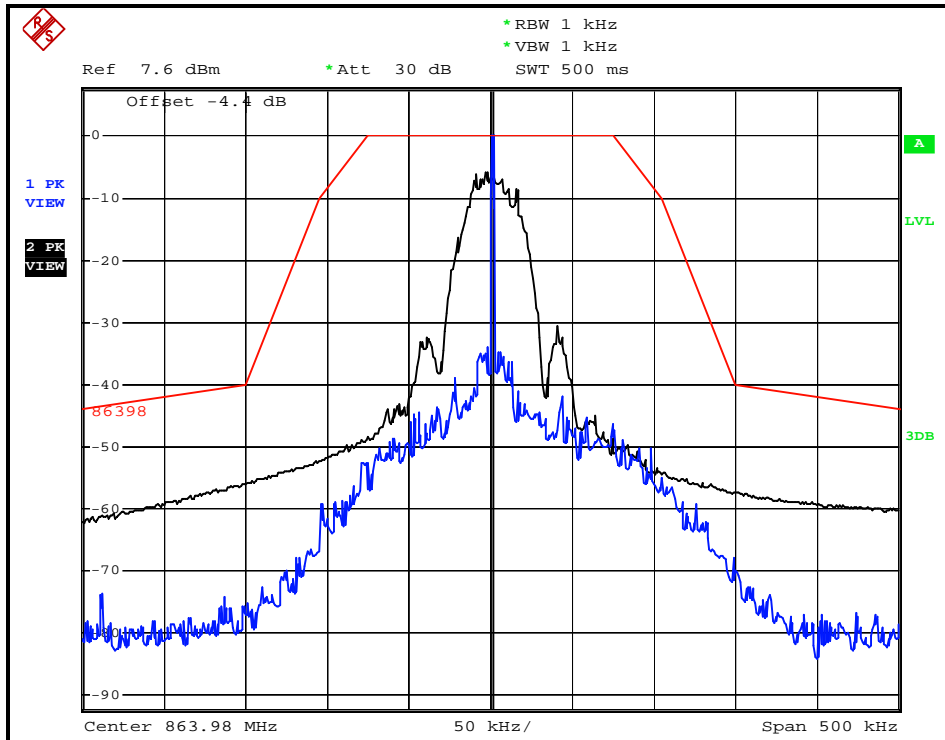

CH 38 3.7V & 20°C

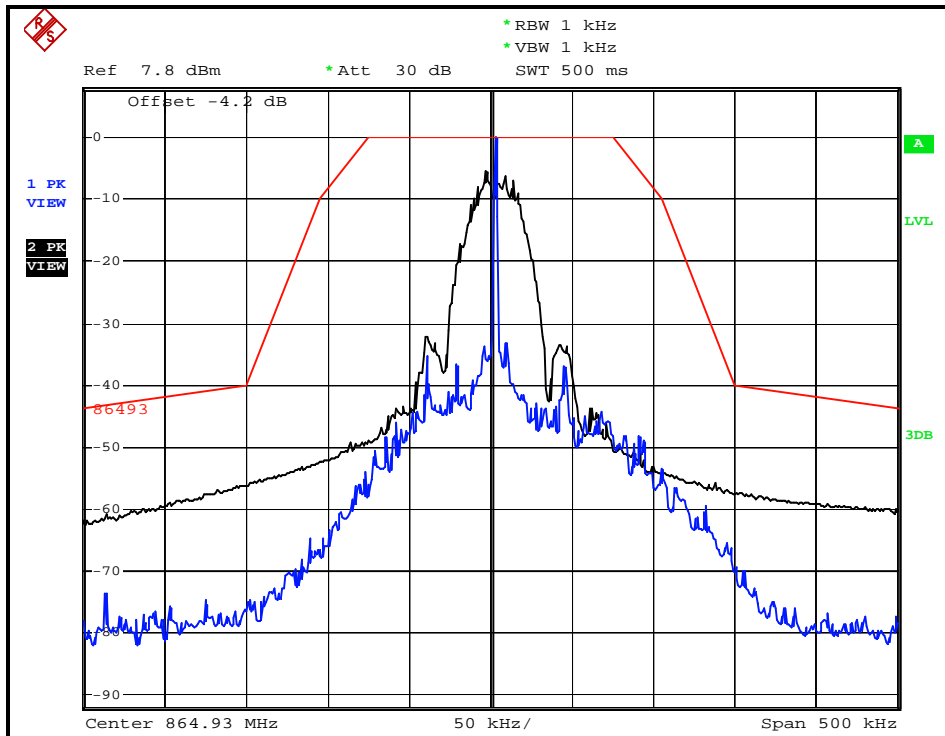



A D T

CH 1 3.7V & 60°C

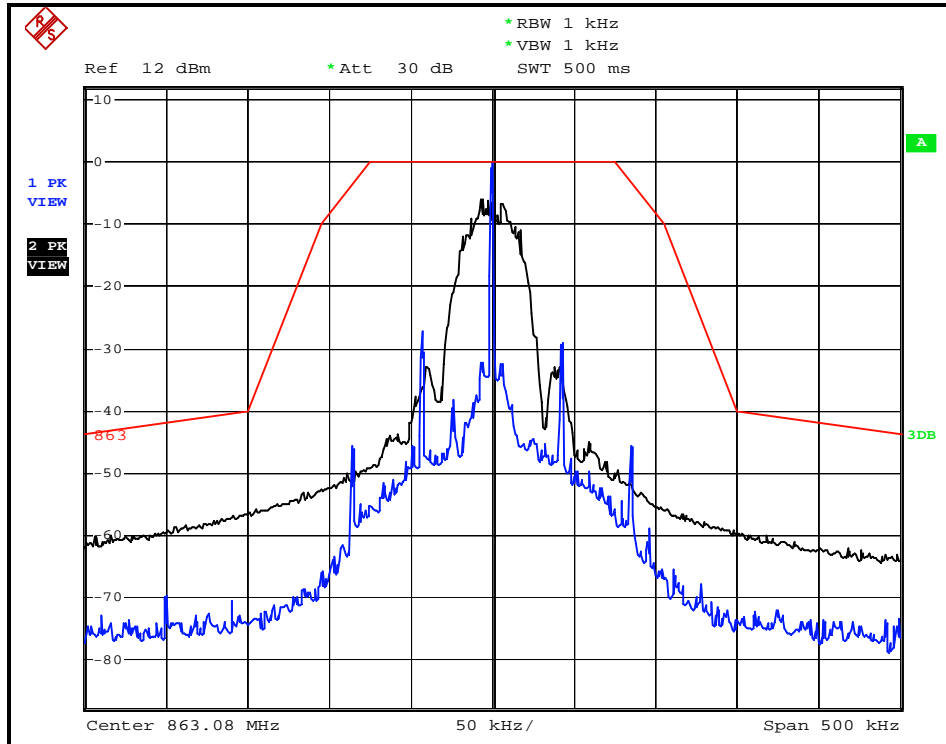

CH 19 3.7V & 60°C

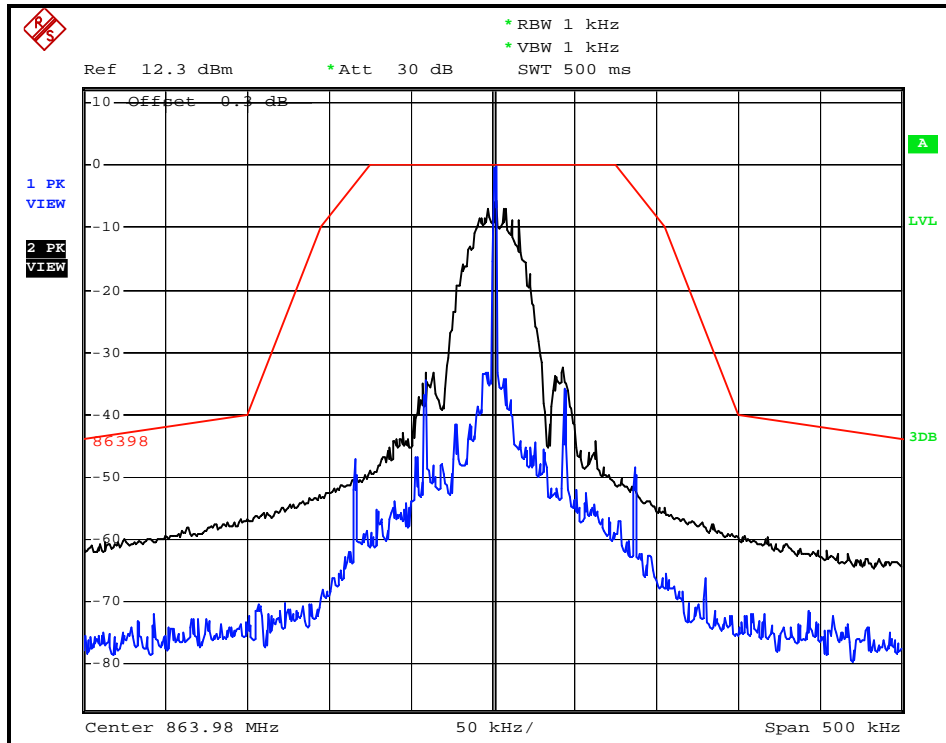



A D T

CH 38 3.7V & 60°C

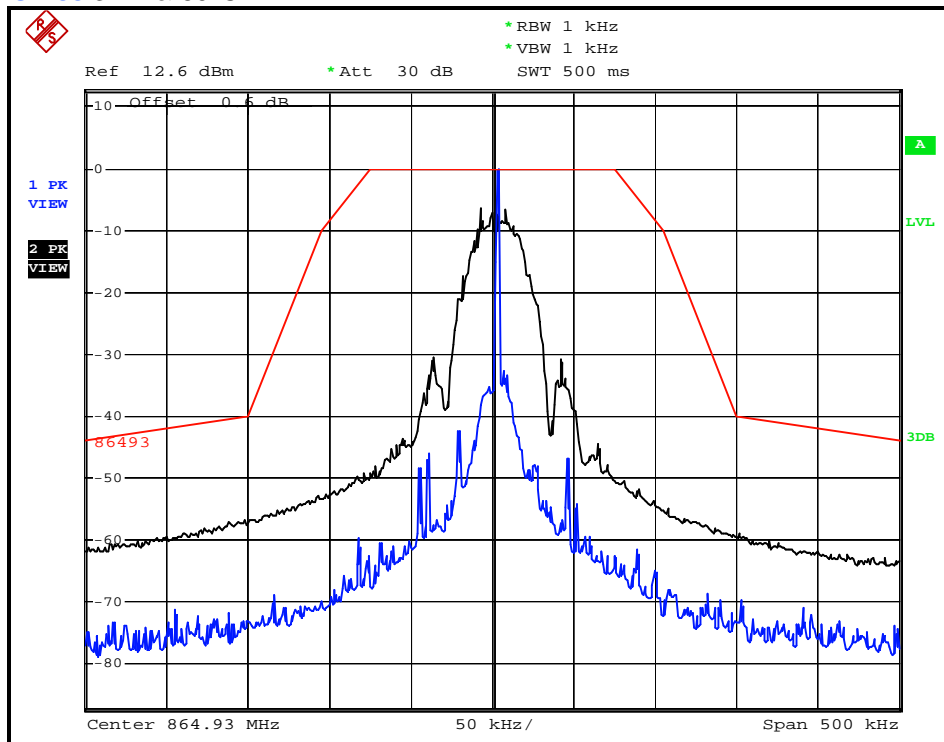

4.4. SPURIOUS EMISSIONS

4.4.1. LIMITS OF SPURIOUS EMISSIONS

STATE	FREQUENCY		
	47MHz to 74MHz 87.5MHz to 118MHz 174MHz to 230MHz 470MHz to 862MHz	Other Frequencies below 1000MHz	Frequencies above 1000MHz
Operation	4nW	250nW	1 μ W
Standby	2nW	2nW	20nW

4.4.2. TEST PROCEDURES

Reference to ETSI EN 301 357-1 V1.4.1 clause 8.6.2.

4.4.3. DEVIATION FROM TEST STANDARD

No deviation.

4.4.4. TEST SETUP

For the actual test configuration, please refer to the related item in this test report (Photographs of the Test Configuration).

4.4.5. TEST RESULTS

BELOW 1GHz WORST-CASE DATA

SPURIOUS EMISSION FREQUENCY RANGE	30MHz ~ 1GHz	OPERATING CHANNEL	1
OPERATING STATE	Operating	TEST MODE	B

SPURIOUS EMISSION LEVEL				
Frequency (MHz)	Antenna Polarization	Level (dBm)	Limit (dBm)	Margin
52.50	H	-70.43	-54.00	-16.43
54.33	H	-69.24	-54.00	-15.24
55.25	V	-64.04	-54.00	-10.04
70.83	V	-66.21	-54.00	-12.21
71.29	V	-62.53	-54.00	-8.53
93.29	V	-68.71	-54.00	-14.71
103.37	V	-69.26	-54.00	-15.26
114.37	V	-66.08	-54.00	-12.08
180.38	H	-67.22	-54.00	-13.22
180.38	V	-65.04	-54.00	-11.04
196.42	V	-67.37	-54.00	-13.37
199.63	V	-65.35	-54.00	-11.35
206.04	H	-68.64	-54.00	-14.64
215.21	V	-67.32	-54.00	-13.32
217.50	H	-66.66	-54.00	-12.66
218.42	V	-65.72	-54.00	-11.72
223.00	H	-64.86	-54.00	-10.86
228.04	H	-68.28	-54.00	-14.28
483.17	H	-65.56	-54.00	-11.56
483.17	V	-65.84	-54.00	-11.84
499.50	H	-68.48	-54.00	-14.48
499.50	V	-66.44	-54.00	-12.44
515.83	H	-69.11	-54.00	-15.11
532.17	V	-68.26	-54.00	-14.26
548.50	H	-69.42	-54.00	-15.42

NOTE: The emission behavior belongs to narrowband spurious emission.

**A D T**

SPURIOUS EMISSION FREQUENCY RANGE	30MHz ~ 1GHz	OPERATING CHANNEL	1
OPERATING STATE	Operating	TEST MODE	B

SPURIOUS EMISSION LEVEL				
Frequency (MHz)	Antenna Polarization	Level (dBm)	Limit (dBm)	Margin
548.50	V	-68.96	-54.00	-14.96
564.83	H	-68.87	-54.00	-14.87
581.17	H	-65.58	-54.00	-11.58
581.17	V	-67.26	-54.00	-13.26
696.67	H	-68.04	-54.00	-14.04
699.00	H	-65.71	-54.00	-11.71
699.00	V	-65.70	-54.00	-11.70
737.50	H	-66.99	-54.00	-12.99
743.33	V	-68.56	-54.00	-14.56
744.50	H	-66.07	-54.00	-12.07
744.50	V	-64.97	-54.00	-10.97
779.50	H	-67.46	-54.00	-13.46
813.33	H	-68.49	-54.00	-14.49
827.33	H	-68.49	-54.00	-14.49
843.67	H	-67.86	-54.00	-13.86

NOTE: The emission behavior belongs to narrowband spurious emission.



A D T

SPURIOUS EMISSION FREQUENCY RANGE	30MHz ~ 1GHz	OPERATING CHANNEL	1
OPERATING STATE	Operating	TEST MODE	C

SPURIOUS EMISSION LEVEL				
Frequency (MHz)	Antenna Polarization	Level (dBm)	Limit (dBm)	Margin
47.00	H	-74.48	-54.00	-20.48
50.21	V	-74.51	-54.00	-20.51
59.83	H	-74.06	-54.00	-20.06
59.83	V	-72.84	-54.00	-18.84
63.04	H	-73.50	-54.00	-19.50
65.79	V	-74.08	-54.00	-20.08
71.75	V	-74.66	-54.00	-20.66
97.87	H	-69.82	-54.00	-15.82
97.87	V	-67.88	-54.00	-13.88
102.00	H	-73.48	-54.00	-19.48
102.00	V	-72.81	-54.00	-18.81
110.25	V	-74.34	-54.00	-20.34
175.33	H	-72.52	-54.00	-18.52
175.33	V	-73.17	-54.00	-19.17
187.25	V	-72.99	-54.00	-18.99
617.33	H	-69.92	-54.00	-15.92
617.33	V	-69.78	-54.00	-15.78
645.33	V	-69.56	-54.00	-15.56
665.17	V	-69.75	-54.00	-15.75
671.00	H	-69.44	-54.00	-15.44
688.50	V	-69.46	-54.00	-15.46
689.67	H	-69.14	-54.00	-15.14
703.67	V	-69.15	-54.00	-15.15
718.83	H	-68.97	-54.00	-14.97
736.33	V	-68.53	-54.00	-14.53
739.83	H	-67.58	-54.00	-13.58
760.83	V	-67.68	-54.00	-13.68

NOTE: The emission behavior belongs to narrowband spurious emission.



A D T

SPURIOUS EMISSION FREQUENCY RANGE	30MHz ~ 1GHz	OPERATING CHANNEL	1
OPERATING STATE	Operating	TEST MODE	C

SPURIOUS EMISSION LEVEL				
Frequency (MHz)	Antenna Polarization	Level (dBm)	Limit (dBm)	Margin
763.17	H	-66.29	-54.00	-12.29
767.83	V	-66.60	-54.00	-12.60
778.33	H	-67.11	-54.00	-13.11
795.83	H	-67.74	-54.00	-13.74
809.83	V	-66.64	-54.00	-12.64
832.00	H	-67.59	-54.00	-13.59
836.67	V	-67.43	-54.00	-13.43
847.17	H	-67.51	-54.00	-13.51
851.83	V	-65.50	-54.00	-11.50

NOTE: The emission behavior belongs to narrowband spurious emission.



A D T

ABOVE 1GHz DATA:

SPURIOUS EMISSION FREQUENCY RANGE	1GHz ~ 1.8GHz	OPERATING CHANNEL	1, 19, 38
OPERATING STATE	Operating	TEST MODE	B

SPURIOUS EMISSION LEVEL					
Channel	Frequency (MHz)	Antenna Polarization	Level (dBm)	Limit (dBm)	Margin (dB)
1	1726.17	H	-59.57	-30.00	-29.57
	1726.17	V	-58.25	-30.00	-28.25
	2589.24	H	-55.91	-30.00	-25.91
	2589.24	V	-54.57	-30.00	-24.57
	3085.34	V	-50.41	-30.00	-20.41
	3085.35	H	-49.57	-30.00	-19.57
19	1727.97	H	-58.94	-30.00	-28.94
	1727.97	V	-57.09	-30.00	-27.09
	2591.93	V	-56.06	-30.00	-26.06
	2591.97	H	-55.89	-30.00	-25.89
	3089.83	H	-49.37	-30.00	-19.37
	3089.88	V	-50.40	-30.00	-20.40
38	1729.84	H	-58.41	-30.00	-28.41
	1729.85	V	-59.10	-30.00	-29.10
	2594.77	V	-56.14	-30.00	-26.14
	2594.78	H	-55.94	-30.00	-25.94
	3094.66	H	-49.79	-30.00	-19.79
	3094.76	V	-50.00	-30.00	-20.00

NOTE: The emission behavior belongs to narrowband spurious emission.



A D T

SPURIOUS EMISSION FREQUENCY RANGE	1GHz ~ 1.8GHz	OPERATING CHANNEL	1, 19, 38
OPERATING STATE	Operating	TEST MODE	C

SPURIOUS EMISSION LEVEL					
Channel	Frequency (MHz)	Antenna Polarization	Level (dBm)	Limit (dBm)	Margin (dB)
1	1726.14	H	-58.63	-30.00	-28.63
	1726.86	V	-58.02	-30.00	-28.02
	2589.25	H	-56.77	-30.00	-26.77
	2589.97	V	-55.93	-30.00	-25.93
	3085.22	H	-49.52	-30.00	-19.52
	3085.33	V	-50.22	-30.00	-20.22
19	1727.94	V	-56.86	-30.00	-26.86
	1727.97	H	-58.59	-30.00	-28.59
	2591.94	H	-56.02	-30.00	-26.02
	2591.95	V	-56.11	-30.00	-26.11
	3089.88	H	-49.10	-30.00	-19.10
	3090.04	V	-50.51	-30.00	-20.51
38	1729.87	H	-58.74	-30.00	-28.74
	1729.88	V	-56.86	-30.00	-26.86
	2594.78	H	-56.37	-30.00	-26.37
	2594.80	V	-56.39	-30.00	-26.39
	3094.68	H	-49.77	-30.00	-19.77
	3094.70	V	-50.21	-30.00	-20.21

NOTE: The emission behavior belongs to narrowband spurious emission.



A D T

SPURIOUS EMISSION FREQUENCY RANGE	30MHz ~ 1GHz	OPERATING STATE	Standby
TEST MODE	A		

SPURIOUS EMISSION LEVEL				
Frequency (MHz)	Antenna Polarization	Level (dBm)	Limit (dBm)	Margin
25.92	V	-61.03	-57.00	-4.03
43.33	V	-63.41	-57.00	-6.41
43.79	V	-62.91	-57.00	-5.91
60.75	H	-67.04	-57.00	-10.04
61.67	V	-60.21	-57.00	-3.21
63.04	H	-64.92	-57.00	-7.92
63.04	V	-58.29	-57.00	-1.29
75.88	V	-64.81	-57.00	-7.81
76.33	H	-69.73	-57.00	-12.73
89.17	V	-64.56	-57.00	-7.56
91.46	V	-62.91	-57.00	-5.91
93.29	H	-69.61	-57.00	-12.61
98.79	V	-64.42	-57.00	-7.42
101.54	H	-67.76	-57.00	-10.76
107.96	V	-68.64	-57.00	-11.64
124.92	V	-69.55	-57.00	-12.55
126.29	V	-70.86	-57.00	-13.86
147.37	H	-64.02	-57.00	-7.02
147.37	V	-64.88	-57.00	-7.88
344.33	H	-67.55	-57.00	-10.55
377.00	H	-67.38	-57.00	-10.38
377.00	V	-67.94	-57.00	-10.94
409.67	H	-67.82	-57.00	-10.82
409.67	V	-65.74	-57.00	-8.74
426.00	V	-68.97	-57.00	-11.97
442.33	H	-67.17	-57.00	-10.17
442.33	V	-64.82	-57.00	-7.82

NOTE: The emission behavior belongs to narrowband spurious emission.



A D T

SPURIOUS EMISSION FREQUENCY RANGE	30MHz ~ 1GHz	OPERATING STATE	Standby
TEST MODE	A		

SPURIOUS EMISSION LEVEL				
Frequency (MHz)	Antenna Polarization	Level (dBm)	Limit (dBm)	Margin
706.00	H	-68.79	-57.00	-11.79
920.67	H	-68.28	-57.00	-11.28
930.00	V	-68.30	-57.00	-11.30
991.83	V	-67.30	-57.00	-10.30
996.50	H	-68.39	-57.00	-11.39

NOTE: The emission behavior belongs to narrowband spurious emission.



A D T

SPURIOUS EMISSION FREQUENCY RANGE	30MHz ~ 1GHz	OPERATING STATE	Standby
TEST MODE	B		

SPURIOUS EMISSION LEVEL				
Frequency (MHz)	Antenna Polarization	Level (dBm)	Limit (dBm)	Margin
26.37	V	-65.49	-57.00	-8.49
40.58	V	-60.84	-57.00	-3.84
41.04	H	-68.16	-57.00	-11.16
48.38	V	-64.76	-57.00	-7.76
53.88	V	-65.32	-57.00	-8.32
70.38	V	-62.95	-57.00	-5.95
71.75	V	-63.21	-57.00	-6.21
114.83	V	-66.90	-57.00	-9.90
121.25	H	-67.14	-57.00	-10.14
124.00	V	-63.35	-57.00	-6.35
135.00	V	-62.72	-57.00	-5.72
136.83	V	-61.62	-57.00	-4.62
147.37	H	-64.98	-57.00	-7.98
147.37	V	-62.95	-57.00	-5.95
180.38	H	-68.32	-57.00	-11.32
180.38	V	-66.31	-57.00	-9.31
198.71	V	-65.66	-57.00	-8.66
203.75	V	-66.82	-57.00	-9.82
210.63	H	-68.10	-57.00	-11.10
220.71	V	-66.39	-57.00	-9.39
223.00	H	-65.26	-57.00	-8.26
227.58	H	-68.15	-57.00	-11.15
344.33	V	-68.40	-57.00	-11.40
360.67	H	-68.98	-57.00	-11.98
377.00	H	-67.74	-57.00	-10.74
377.00	V	-68.80	-57.00	-11.80

NOTE: The emission behavior belongs to narrowband spurious emission.



A D T

SPURIOUS EMISSION FREQUENCY RANGE	30MHz ~ 1GHz	OPERATING STATE	Standby
TEST MODE	B		

SPURIOUS EMISSION LEVEL				
Frequency (MHz)	Antenna Polarization	Level (dBm)	Limit (dBm)	Margin
442.33	H	-68.54	-57.00	-11.54
442.33	V	-68.96	-57.00	-11.96
699.00	V	-67.37	-57.00	-10.37
735.17	H	-68.39	-57.00	-11.39
738.67	V	-68.09	-57.00	-11.09
744.50	H	-68.07	-57.00	-11.07
748.00	V	-67.64	-57.00	-10.64
783.00	H	-68.07	-57.00	-11.07
787.67	V	-68.35	-57.00	-11.35
805.17	V	-67.74	-57.00	-10.74
815.67	V	-67.62	-57.00	-10.62
818.00	H	-68.49	-57.00	-11.49
839.00	H	-68.19	-57.00	-11.19
850.67	V	-68.19	-57.00	-11.19
864.67	H	-68.81	-57.00	-11.81
875.17	V	-68.52	-57.00	-11.52
899.67	V	-68.29	-57.00	-11.29
902.00	H	-67.13	-57.00	-10.13
913.67	V	-63.26	-57.00	-6.26
916.00	H	-67.88	-57.00	-10.88
994.17	H	-67.76	-57.00	-10.76
1000.00	V	-66.39	-57.00	-9.39

NOTE: The emission behavior belongs to narrowband spurious emission.



A D T

SPURIOUS EMISSION FREQUENCY RANGE	30MHz ~ 1GHz	OPERATING STATE	Standby
TEST MODE	C		

SPURIOUS EMISSION LEVEL				
Frequency (MHz)	Antenna Polarization	Level (dBm)	Limit (dBm)	Margin
25.46	H	-71.52	-57.00	-14.52
61.05	V	-75.70	-57.00	-18.70
66.25	H	-73.74	-57.00	-16.74
66.45	V	-75.87	-57.00	-18.87
80.00	H	-70.36	-57.00	-13.36
91.65	V	-67.05	-57.00	-10.05
91.92	H	-69.97	-57.00	-12.97
100.62	H	-71.75	-57.00	-14.75
101.55	V	-67.34	-57.00	-10.34
103.35	V	-72.08	-57.00	-15.08
154.20	V	-75.66	-57.00	-18.66
160.05	V	-75.71	-57.00	-18.71
245.10	V	-73.74	-57.00	-16.74
284.88	H	-71.04	-57.00	-14.04
285.15	V	-75.61	-57.00	-18.61
736.33	V	-67.61	-57.00	-10.61
764.33	H	-67.04	-57.00	-10.04
779.50	H	-67.45	-57.00	-10.45
797.00	V	-67.73	-57.00	-10.73
819.17	V	-67.44	-57.00	-10.44
850.67	H	-67.88	-57.00	-10.88
874.00	H	-67.22	-57.00	-10.22
876.33	V	-68.00	-57.00	-11.00
885.67	H	-67.14	-57.00	-10.14
904.33	V	-67.59	-57.00	-10.59
925.33	V	-66.68	-57.00	-9.68
927.67	H	-64.93	-57.00	-7.93

NOTE: The emission behavior belongs to narrowband spurious emission.



A D T

SPURIOUS EMISSION FREQUENCY RANGE	30MHz ~ 1GHz	OPERATING STATE	Standby
TEST MODE	C		

SPURIOUS EMISSION LEVEL				
Frequency (MHz)	Antenna Polarization	Level (dBm)	Limit (dBm)	Margin
987.17	H	-65.37	-57.00	-8.37
997.67	V	-64.53	-57.00	-7.53

NOTE: The emission behavior belongs to narrowband spurious emission.



A D T

SPURIOUS EMISSION FREQUENCY RANGE	30MHz ~ 1GHz	OPERATING STATE	Standby
TEST MODE	D		

SPURIOUS EMISSION LEVEL				
Frequency (MHz)	Antenna Polarization	Level (dBm)	Limit (dBm)	Margin
32.70	H	-72.66	-57.00	-15.66
55.65	H	-73.65	-57.00	-16.65
62.40	H	-72.00	-57.00	-15.00
65.10	V	-60.29	-57.00	-3.29
68.25	H	-67.06	-57.00	-10.06
73.20	V	-61.01	-57.00	-4.01
75.45	V	-64.25	-57.00	-7.25
97.95	H	-73.16	-57.00	-16.16
149.25	V	-61.82	-57.00	-4.82
158.70	H	-70.57	-57.00	-13.57
162.75	V	-62.14	-57.00	-5.14
165.90	H	-71.23	-57.00	-14.23
173.55	V	-65.05	-57.00	-8.05
187.50	H	-73.86	-57.00	-16.86
277.50	H	-73.61	-57.00	-16.61
293.25	H	-74.00	-57.00	-17.00
738.67	H	-65.77	-57.00	-8.77
742.17	V	-66.03	-57.00	-9.03
759.67	H	-65.67	-57.00	-8.67
765.50	V	-66.36	-57.00	-9.36
778.33	V	-66.59	-57.00	-9.59
779.50	H	-66.62	-57.00	-9.62
791.17	H	-66.11	-57.00	-9.11
809.83	V	-65.12	-57.00	-8.12
820.33	V	-65.54	-57.00	-8.54
834.33	H	-66.76	-57.00	-9.76
844.83	V	-65.59	-57.00	-8.59

NOTE: The emission behavior belongs to narrowband spurious emission.



A D T

SPURIOUS EMISSION FREQUENCY RANGE	30MHz ~ 1GHz	OPERATING STATE	Standby
TEST MODE	D		

SPURIOUS EMISSION LEVEL				
Frequency (MHz)	Antenna Polarization	Level (dBm)	Limit (dBm)	Margin
846.00	H	-66.60	-57.00	-9.60
870.50	H	-65.75	-57.00	-8.75
872.83	V	-65.42	-57.00	-8.42
885.67	V	-66.00	-57.00	-9.00
996.50	H	-65.07	-57.00	-8.07
998.83	V	-64.31	-57.00	-7.31

NOTE: The emission behavior belongs to narrowband spurious emission.



A D T

ABOVE 1GHz DATA:

SPURIOUS EMISSION FREQUENCY RANGE	1GHz ~ 1.8GHz	OPERATING STATE	Standby
TEST MODE	B		

SPURIOUS EMISSION LEVEL				
Frequency (MHz)	Antenna Polarization	Level (dBm)	Limit (dBm)	Margin
1726.11	H	-59.65	-47.00	-12.65
1726.11	V	-58.85	-47.00	-11.85
2589.22	V	-55.73	-47.00	-8.73
2589.26	H	-55.99	-47.00	-8.99

NOTE: The emission behavior belongs to narrowband spurious emission.



A D T

SPURIOUS EMISSION FREQUENCY RANGE	1GHz ~ 1.8GHz	OPERATING STATE	Standby
TEST MODE	C		

SPURIOUS EMISSION LEVEL				
Frequency (MHz)	Antenna Polarization	Level (dBm)	Limit (dBm)	Margin
1726.17	V	-58.55	-47.00	-11.55
1726.22	H	-59.83	-47.00	-12.83
2589.24	V	-55.88	-47.00	-8.88
2589.31	H	-55.89	-47.00	-8.89

NOTE: The emission behavior belongs to narrowband spurious emission.

RECEIVER PARAMETERS

4.5. RECEIVER SPURIOUS RADIATION

4.5.1. LIMIT OF RECEIVER SPURIOUS RADIATION

MEASUREMENT	25MHz TO 1000MHz	FREQUENCIES ABOVE 1000MHz
e.r.p	2nW	20nW

4.5.2. TEST PROCEDURES

Reference to ETSI EN 301 357-1 V1.4.1 clause 9.1.2.

4.5.3. DEVIATION FROM TEST STANDARD

No deviation.

4.5.4. TEST SETUP

For the actual test configuration, please refer to the related Item in this test report (Photographs of the Test Configuration).

4.5.5. TEST RESULTS

WORST-CASE DATA:

SPURIOUS EMISSION FREQUENCY RANGE	30MHz ~ 1GHz	OPERATING CHANNEL	1
TEST MODE	B		

SPURIOUS EMISSION LEVEL				
Frequency (MHz)	Antenna Polarization	Level (dBm)	Limit (dBm)	Margin
33.15	V	-68.96	-57.00	-11.96
39.90	V	-65.12	-57.00	-8.12
42.60	H	-71.98	-57.00	-14.98
53.40	H	-69.79	-57.00	-12.79
55.20	V	-64.70	-57.00	-7.70
57.45	V	-69.59	-57.00	-12.59
64.65	H	-73.48	-57.00	-16.48
70.95	V	-66.14	-57.00	-9.14
71.85	H	-72.08	-57.00	-15.08
75.45	H	-72.94	-57.00	-15.94
75.90	V	-67.30	-57.00	-10.30
85.80	V	-69.76	-57.00	-12.76
100.65	H	-73.89	-57.00	-16.89
114.60	V	-67.90	-57.00	-10.90
122.25	H	-71.93	-57.00	-14.93
124.95	V	-68.16	-57.00	-11.16
134.85	V	-66.73	-57.00	-9.73
139.80	V	-69.76	-57.00	-12.76
147.45	H	-65.43	-57.00	-8.43
147.45	V	-62.85	-57.00	-5.85
180.30	H	-68.99	-57.00	-11.99
180.30	V	-65.86	-57.00	-8.86
209.10	H	-72.09	-57.00	-15.09
211.35	H	-72.62	-57.00	-15.62
221.25	H	-73.72	-57.00	-16.72
311.67	H	-69.16	-57.00	-12.16

NOTE: The emission behavior belongs to narrowband spurious emission.



A D T

SPURIOUS EMISSION FREQUENCY RANGE	30MHz ~ 1GHz	OPERATING CHANNEL	1
TEST MODE	B		

SPURIOUS EMISSION LEVEL				
Frequency (MHz)	Antenna Polarization	Level (dBm)	Limit (dBm)	Margin
344.33	H	-67.17	-57.00	-10.17
344.33	V	-68.16	-57.00	-11.16
377.00	H	-67.19	-57.00	-10.19
377.00	V	-69.18	-57.00	-12.18
409.67	H	-69.95	-57.00	-12.95
442.33	H	-69.26	-57.00	-12.26
699.00	H	-65.98	-57.00	-8.98
699.00	V	-66.22	-57.00	-9.22
738.67	H	-69.89	-57.00	-12.89
763.17	H	-69.10	-57.00	-12.10
772.50	H	-69.54	-57.00	-12.54
792.33	V	-69.70	-57.00	-12.70
819.17	V	-69.39	-57.00	-12.39
839.00	V	-69.97	-57.00	-12.97
876.33	V	-69.56	-57.00	-12.56
878.67	H	-69.17	-57.00	-12.17
892.67	H	-68.75	-57.00	-11.75
917.17	V	-68.48	-57.00	-11.48
930.00	H	-67.82	-57.00	-10.82
995.33	V	-67.82	-57.00	-10.82
998.83	H	-69.25	-57.00	-12.25

NOTE: The emission behavior belongs to narrowband spurious emission.



A D T

SPURIOUS EMISSION FREQUENCY RANGE	30MHz ~ 1GHz	OPERATING CHANNEL	1
TEST MODE	C		

SPURIOUS EMISSION LEVEL				
Frequency (MHz)	Antenna Polarization	Level (dBm)	Limit (dBm)	Margin
25.00	V	-73.06	-57.00	-16.06
26.37	H	-71.76	-57.00	-14.76
35.08	H	-74.11	-57.00	-17.11
47.00	H	-74.48	-54.00	-20.48
57.08	H	-73.88	-57.00	-16.88
59.83	V	-73.53	-57.00	-16.53
59.83	H	-74.06	-54.00	-20.06
63.04	H	-73.50	-54.00	-19.50
64.42	H	-74.09	-57.00	-17.09
65.79	V	-73.82	-57.00	-16.82
97.87	H	-69.14	-57.00	-12.14
97.87	V	-68.18	-57.00	-11.18
97.87	H	-69.82	-54.00	-15.82
101.54	H	-73.03	-57.00	-16.03
101.54	V	-72.53	-57.00	-15.53
102.00	H	-73.48	-54.00	-19.48
150.58	V	-73.53	-57.00	-16.53
160.67	H	-73.97	-57.00	-16.97
160.67	V	-73.27	-57.00	-16.27
175.33	H	-72.97	-57.00	-15.97
175.33	V	-73.55	-57.00	-16.55
175.33	H	-72.52	-54.00	-18.52
742.17	V	-68.35	-57.00	-11.35
757.33	V	-67.12	-57.00	-10.12
770.17	V	-67.97	-57.00	-10.97
794.67	V	-67.67	-57.00	-10.67
830.83	V	-66.85	-57.00	-9.85
843.67	V	-67.23	-57.00	-10.23

NOTE: The emission behavior belongs to narrowband spurious emission.



A D T

SPURIOUS EMISSION FREQUENCY RANGE	30MHz ~ 1GHz	OPERATING CHANNEL	1
TEST MODE	C		

SPURIOUS EMISSION LEVEL				
Frequency (MHz)	Antenna Polarization	Level (dBm)	Limit (dBm)	Margin
871.67	V	-66.35	-57.00	-9.35
899.67	V	-66.73	-57.00	-9.73
930.00	V	-66.14	-57.00	-9.14
995.33	V	-65.55	-57.00	-8.55

NOTE: The emission behavior belongs to narrowband spurious emission.



A D T

SPURIOUS EMISSION FREQUENCY RANGE	1GHz ~ 18GHz	OPERATING CHANNEL	1, 19 & 38
TEST MODE	B		

SPURIOUS EMISSION LEVEL					
Channel	Frequency (MHz)	Antenna Polarization	Level (dBm)	Limit (dBm)	Margin (dB)
1	1726.12	H	-58.74	-47.00	-11.74
	1726.14	V	-58.75	-47.00	-11.75
	2589.24	H	-56.11	-47.00	-9.11
	2589.25	V	-55.16	-47.00	-8.16
	3085.25	V	-50.07	-47.00	-3.07
	3085.31	H	-49.33	-47.00	-2.33
19	1727.93	V	-58.41	-47.00	-11.41
	1727.95	H	-58.68	-47.00	-11.68
	2591.94	H	-56.32	-47.00	-9.32
	2591.95	V	-56.06	-47.00	-9.06
	3089.88	H	-49.31	-47.00	-2.31
	3090.00	V	-50.33	-47.00	-3.33
38	1729.84	V	-58.73	-47.00	-11.73
	1729.88	H	-58.79	-47.00	-11.79
	2594.76	V	-55.96	-47.00	-8.96
	2594.77	H	-55.25	-47.00	-8.25
	3094.72	V	-50.23	-47.00	-3.23
	3094.76	H	-49.85	-47.00	-2.85

NOTE: The emission behavior belongs to narrowband spurious emission.



A D T

SPURIOUS EMISSION FREQUENCY RANGE	1GHz ~ 18GHz	OPERATING CHANNEL	1, 19 & 38
TEST MODE	C		

SPURIOUS EMISSION LEVEL					
Channel	Frequency (MHz)	Antenna Polarization	Level (dBm)	Limit (dBm)	Margin (dB)
1	1726.13	V	-59.41	-47.00	-12.41
	1726.16	H	-59.45	-47.00	-12.45
	2589.22	V	-56.14	-47.00	-9.14
	2589.24	H	-56.64	-47.00	-9.64
	3085.26	H	-49.42	-47.00	-2.42
	3085.37	V	-50.16	-47.00	-3.16
19	1727.94	H	-59.74	-47.00	-12.74
	1727.98	V	-59.61	-47.00	-12.61
	2591.92	H	-56.34	-47.00	-9.34
	2591.92	V	-56.09	-47.00	-9.09
	3089.83	H	-49.23	-47.00	-2.23
	3090.08	V	-50.41	-47.00	-3.41
39	1729.81	V	-59.04	-47.00	-12.04
	1729.86	H	-58.98	-47.00	-11.98
	2594.76	V	-55.70	-47.00	-8.70
	2594.81	H	-55.60	-47.00	-8.60
	3094.72	H	-49.81	-47.00	-2.81
	3094.77	V	-50.25	-47.00	-3.25

NOTE: The emission behavior belongs to narrowband spurious emission.

5. PHOTOGRAPHS OF THE TEST CONFIGURATION

TX and RX Spurious Emission
Test Mode A

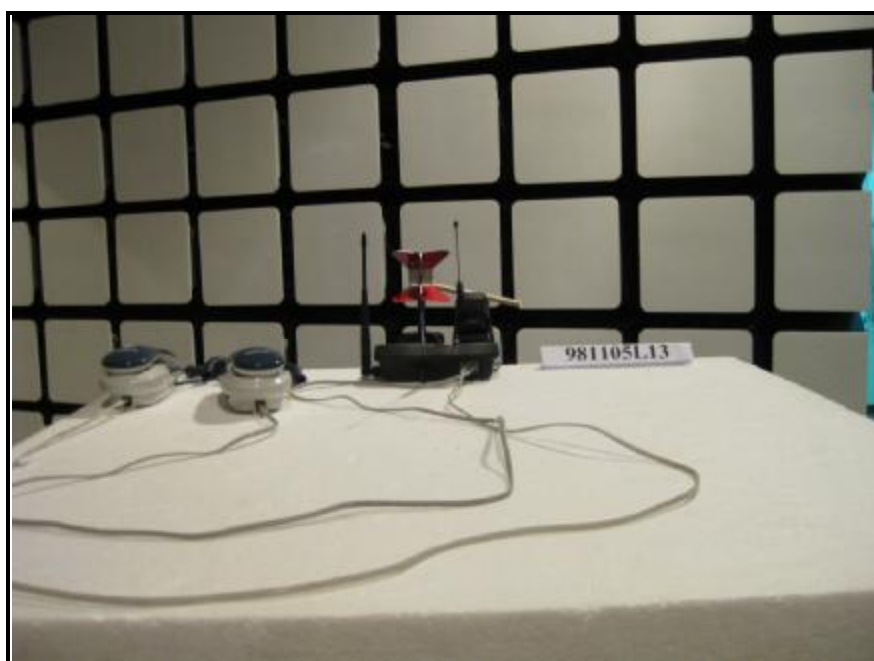

Test Mode B



Test Mode C



Test Mode D

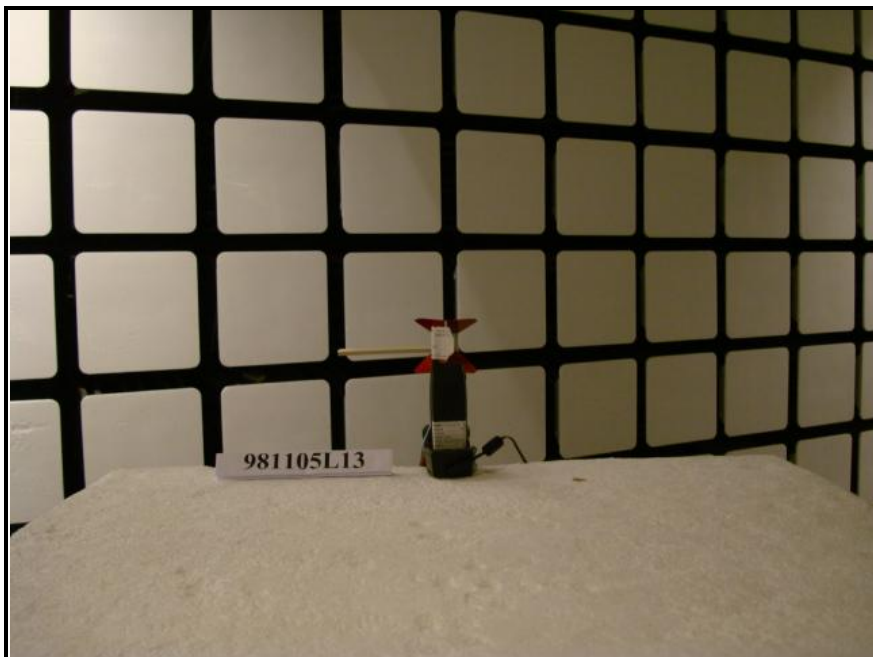



6. INFORMATION ON THE TESTING LABORATORIES

We, Bureau Veritas Consumer Products Services (H.K.) Ltd., Taoyuan Branch, were founded in 1988 to provide our best service in EMC, Radio, Telecom and Safety consultation. Our laboratories are accredited and approved according to ISO/IEC 17025:

Copies of accreditation certificates of our laboratories obtained from approval agencies can be downloaded from our web site: www.adt.com.tw/index.5/phtml. If you have any comments, please feel free to contact us at the following:

Linko EMC/RF Lab

Tel: 886-2-26052180

Fax: 886-2-26051924

Hsin Chu EMC/RF Lab

Tel: 886-3-5935343

Fax: 886-3-5935342

Hwa Ya EMC/RF/Safety/Telecom Lab

Tel: 886-3-3183232

Fax: 886-3-3185050

Web Site: www.adt.com.tw

The address and road map of all our labs can be found in our web site also.

--- END ---